

1

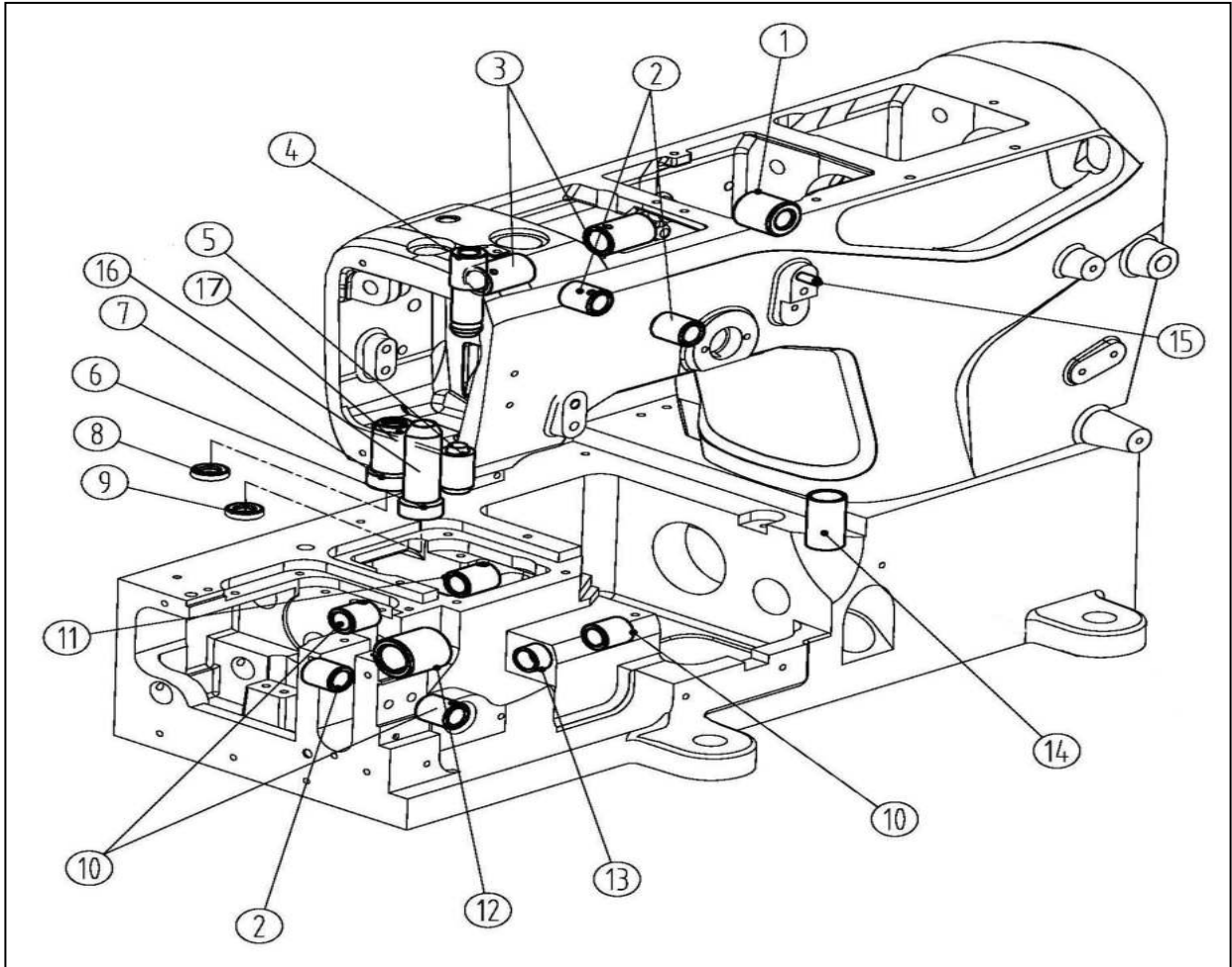

## 一、套筒部件 (Bushing assemblies)

序号Ref. No	公司件号 Part No	参考件号 Ref. Part.	名称	Description	数量 Number
1	31003002		抬压轴套筒	sleeve	1
2	30103106	210297	过线座轴套筒	sleeve	2
3	20103047	250141	送布轴套	sleeve	2
4	30103017	250146	针杆上套	sleeve	1
5	30103062	251003	针杆下套	sleeve	1
6	30103035	250147	压脚轴套筒	sleeve	1
7	30103038	250136	喂针摆动轴套筒	sleeve	1
8	20622019		油封	plug	1
9	30122039		油封	plug	1
10	30103105		前弯针轴后套筒	bushing	3
11	30103021	250135	弯针轴前后套筒	plug	1
12	30103010		主轴套筒	bushing	1
13	30103019		护针轴前套筒	bushing	1
14	30221016	255020	铜油管	pipe	1
15	P03005		销 4×8	pin	1
16	001006		O型圈8.5x1.8		1
17	001008		O型圈9x1.8		1

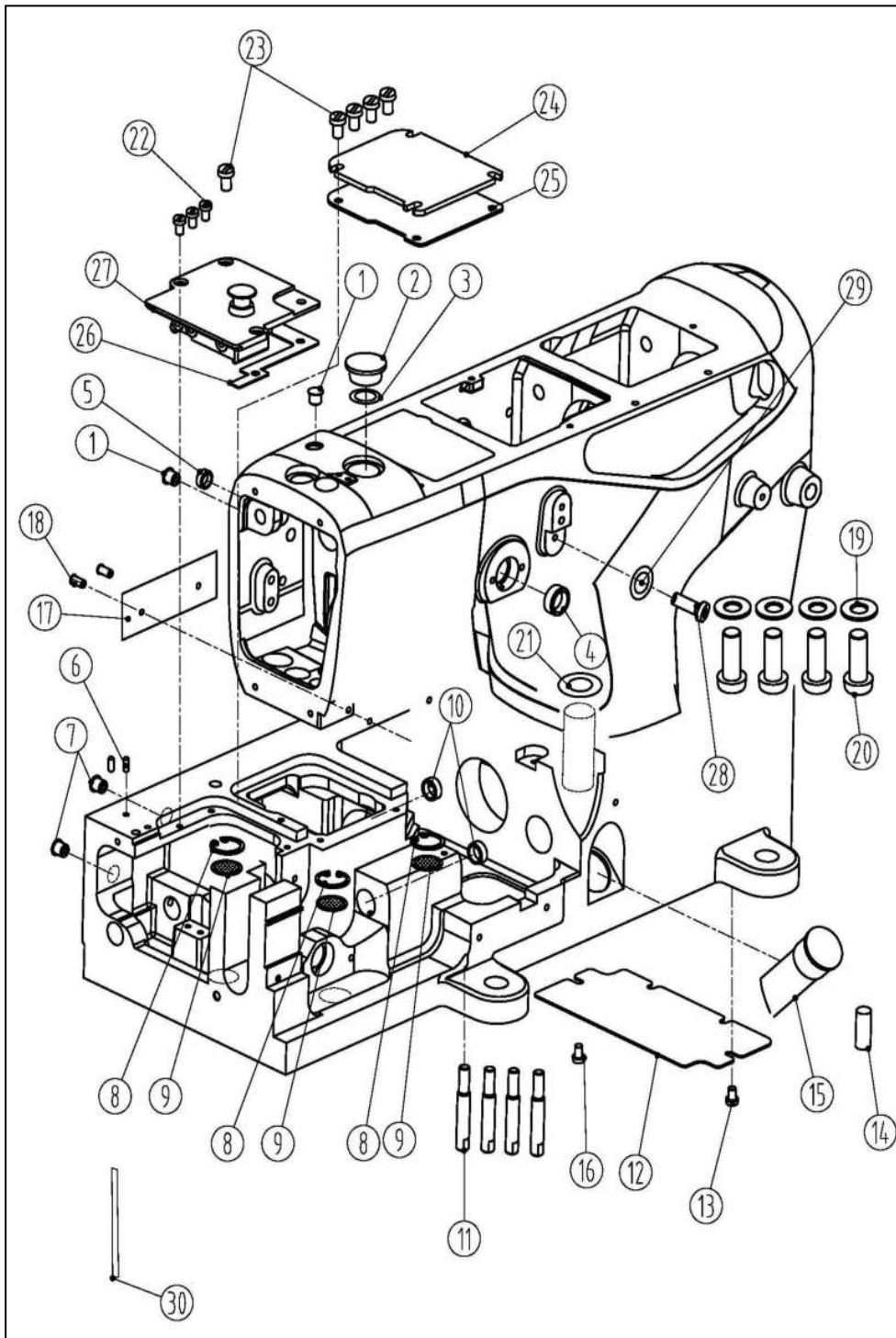

## 二、车壳部件 (Frame assemblies)

序号Ref. No	公司件号 Part No	参考件号 Ref. Part.	名称	Description	数量Number
1	30122006		油封	plug	2
2	21022007	206590	油封	plug	1
3	21012018		油封垫	washer	1
4	20622019		油封	plug	2
5	30122008		油封	plug	1
6	P01001		销A5×13	pin	2
7	30122006	240052	油堵	plug	2
8	H01001	240001	挡圈	ring	3
9	30112001	255002	滤油网	filter	3
10	30122008	208173	油封	plug	2
11	301s30001	250117	机壳螺钉	shoulder pin	4
12	30112002	250049	盖板	cover	1
13	s01002	7017	螺钉M4X6.5	screw	1
14	10126021		拼装销	pin	2
15	30111001	206590	油标	oil level	1
16	s01002	7017	螺钉M4X6.5	screw	1
17	30137001	250233	机型牌	sticker	1
18	R03001	210679	铆钉 2.5×4	pin	2
19	W02003		垫圈 10	washer	4
20	S05001		螺钉 M10×27.5	screw	4
21	001001		O型圈 15×2.65	o ring	1
22	301s11024		滑块导座螺钉	screw	3
23	L02001	7084	螺钉 M4×8	screw	5
24	30101005	250003	下节右盖	top cover (right)	1
25	30122003	250004	下节右盖垫	gasket	1
26	30122002	250020	下节左盖垫	gasket	1
27	30101004	250069	下节左盖	top cover plate (left)	1
	(30101162) 23 机型		下节左盖 (23机 型)		1
28	S01004		GB/T65-1985螺钉 M4×7.8		1
29	W01001		GB/T 97.1-2002 M4垫片(普通)		1
30	30123028		JK-8569-0435油棉		1

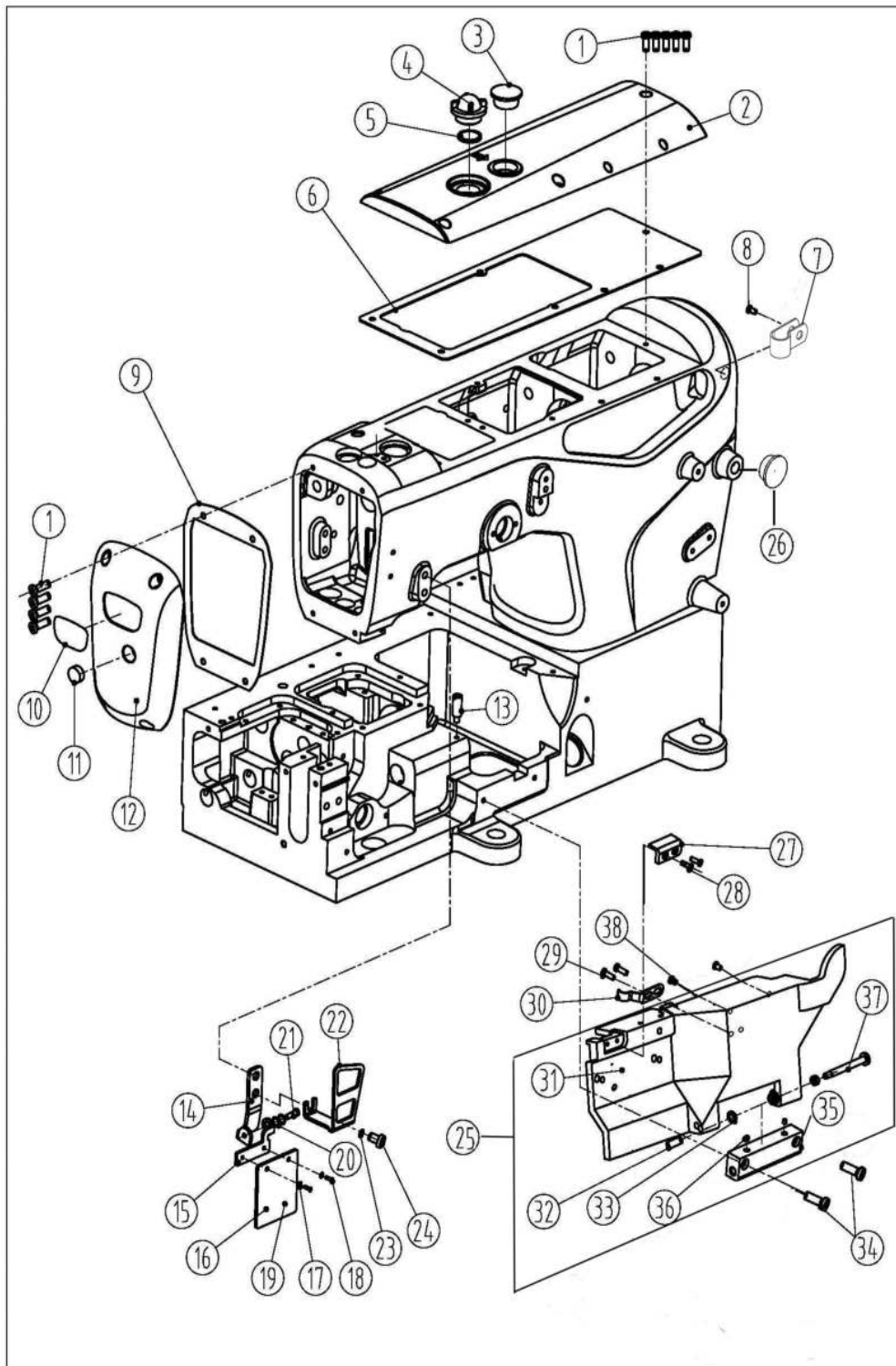

### 三、 罩壳部件(Cover assemblies)

序号Ref. No	公司件号 Part No	参考件号 Ref. Part. no	名称	Description	数量 Number
1	s04060	7021	螺钉M4×10	screw	9
2	303600		上盖(喷漆)	arm cover(top)	1
3	20722002		油封	plug	1
4	20711055		油窗	Oil Sight	1
5	21022003		油窗垫	o ring	1
6	31022010		上盖密封垫	The head	1
7	20711212		R型线夹8.6		1
8	S01002		螺钉 M4×6.5		1
9	31122001		机头左盖密封垫	o ring	1
10	13837002		商标牌	plug	1
11	10122003		油封	plug	1
12	303795		机头左盖(喷漆)	arm	1
13	301S30002	7089	左侧盖簧螺钉	screw	1
14	31012042		玻璃罩安装板	glass plate	1
15	31012029		护罩架	shield	1
16	30111003	250257	有机玻璃罩	eye guard	1
17	W01002	202875	垫圈	sticker	2
18	S01006	7009	螺钉M3x4.5	screw	2
19	20131063		护罩警示牌	sticker	1
20	W03001	210307	波形垫圈	washer	2
21	301S20001		螺钉	screw	1
22	31012012		过线护罩	threan takeup cover	1
23	W02004	303335	垫圈6	sticker	1
24	S01060	7052	护罩螺钉	screw	2
25	300951		前门板缝台	screw	1
26	31022015		油封		1
27	31009005		针板座接块	block	1
28	S01006	7009	螺钉M3x4.5	screw	2
29	S01002	7017	螺钉M4x6.5	screw	2
30	30127001	250051	前罩簧	flat spring	1
31	30101110		JK-8568A-W2-38前罩	arm cover	1
32	301S20003	250014	前罩缝台螺钉	pin	1
33	30128002	201191	弹簧垫圈	spring	3
34	S01007	7023	螺钉M4x13.5	screw	2
35	30101063		前罩缝台座	bracket	1
36	S10006	4539	螺钉M5x6	screw	2
37	301S20002	250013	前罩缝台座螺钉	screw	1
38	30122015		前罩防震垫	cushion	2

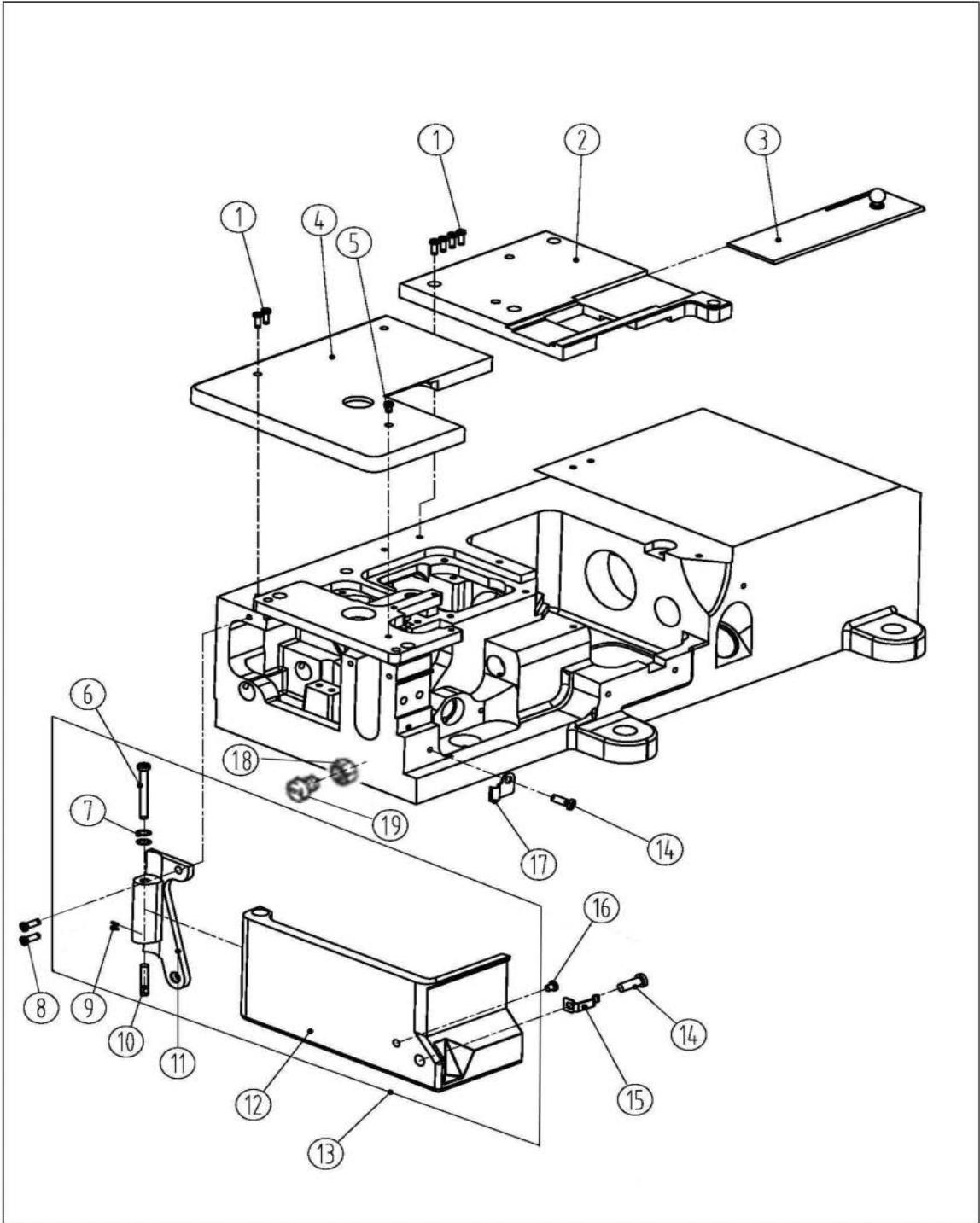

#### 四、 缝台部件(Cloth plate assemblies)

序号 Ref.No	公司件号 Part No	参考件号 Ref. Part.	名称	Description	数量 Number
1	s01003	7021	螺钉 M4×12	screw	6
2	300137	250074-ASD	右缝台盖(喷漆)	bed	1
3	30115001	250071-91	推板	cover	1
4	300953	250052-BSD	左缝台盖(喷漆)	bed	1
5	s02001	7043	螺钉 M4×6	screw	1
6	301s20004		侧盖合扇销钉	screw	1
7	30128002	201191	弹簧垫圈	spring	2
8	s01005	7020	螺钉 M4×10	screw	4
9	s10001		螺钉M3X4	screw	2
10	301s20005		销螺钉	pin	1
11	30101112		侧盖合扇	cover	1
12	30101111		侧盖	side cover	1
13	300952		侧盖组件(喷漆)	side coverassy	1
14	s01002	7017	螺钉M4X6.5	screw	2
15	31127001		侧前锁紧簧	flat spring	1
16	30122015		前罩防震垫	cushion	1
17	30112095		侧前锁紧舌	flat spring	1
18	S01005		螺钉 M4×10		1
19	N01001		螺母M4		1

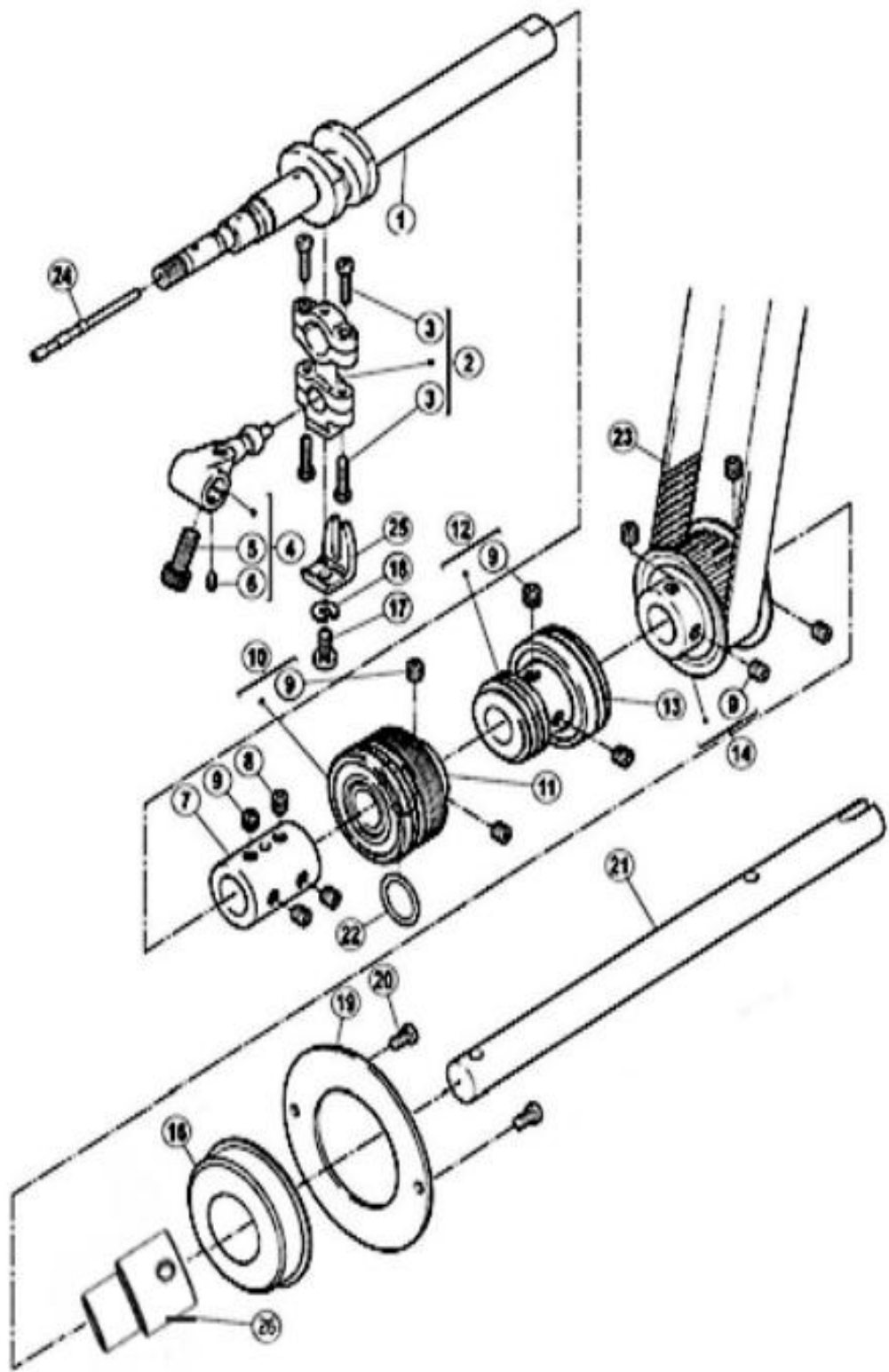

## 五、 下轴部件(Hook shaft assemblies)

序号 Ref.No	公司件号 Part No	参考件号 Ref. Part.	名称	Description	数量 Number
1	400068	250501B-91	主轴	crankshaft	1
2	400060	2505009-92	连杆组件	connection	1
3	(201S20015)	7015	螺钉 M3.5×13	screw	4
4	30104002	252008	下轴曲柄	crank	1
5	S05002	4534	螺钉 M6×0.75×15.2	screw	1
6	S12002	4545	螺钉 M3×4	screw	1
7	30103004	250506	接轴套	joint	1
8	S12003	4555	螺钉 M6×7	screw	1
9	S10029	4547	螺钉 M6×0.75×5	screw	11
10	3012400300	250508-91	油封轴承	bearing	1
11	30103006	250508	中轴套	bushing	1
12	30103008	250543	蜗杆	bushing	1
13	3012400400		油封轴承	bearing	1
14	3112500100	250511-1	下轴同步带轮组件	gear(lower)	1
16	B01003	250504-91	轴承 6304Z	bearing	1
17	301S11004	4019	比叉螺钉	screw	1
18	W02001	202286	M5 弹垫	washer	1
19	30108001	250514	轴承挡圈	cover	1
20	207S11007	7019	螺钉 M4×7.8	screw	2
21	31102001	250507	下后轴	shaft	1
22	001001	206837	O型圈 15×2.65	o ring	1
23	30135021	206050C	同步带	timing belt	1
24	30126001	250525	调节销	adjusting bar	1
25	30109001	201074	比叉	guide	1
26	30103014		轴承套		1

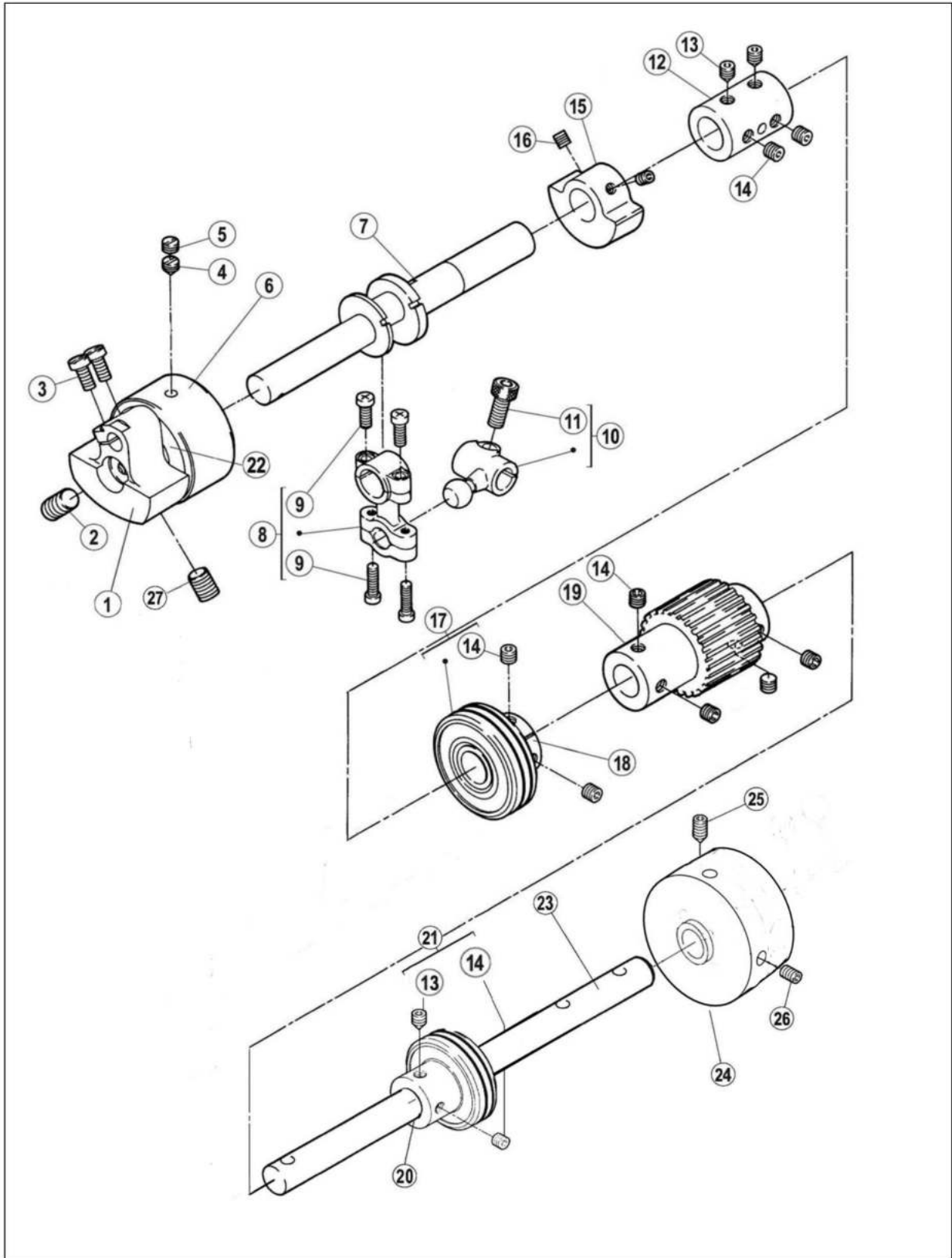

## 六、 上轴部件(Main shaft assemblies)

序号 Ref.No	公司件号 Part No	参考件号 Ref. Part.	名称	Description	数量 Number
1	31104002	250526B92	针杆曲柄	motion assy	1
2	S10004	4592	螺钉 M8×1×12	screw	1
3	S01011	7028	螺钉 M5×10	screw	2
4	S08001		螺钉 M6×0.75×3.5		1
5	S11001	7152	螺钉 M6×0.75×6	screw	1
6	30224005		JK-8669B-0505针杆衬套	bushing	1
7	400065	250517A	上前轴	crankshaft	1
8	400061	253500-92	连杆组件	connection	1
9	(201S20015)	7021	铜连杆螺丝	screw	4
10	30104006	253501A	弯针曲柄	crank assy	1
11	S05002	4534	螺钉 M6×0.75×15.2	screw	1
12	31003004	250506	接轴套	joint	1
13	S12003	4555	螺钉 M6×0.75×7	screw	3
14	S10029	4547	螺钉 M6×0.75×5	screw	9
15	30109003	250524	上轴平衡块	balance weight	1
16	S10002	4514	螺钉 M5×5	screw	2
17	3012400400	250529-91	油封轴承	bushing	1
18	30103107	250529	轴承套(短)(粉末冶金)	bushing	1
19	30125002	250521	上轴同步带轮	gear (upper)	1
20	30103108	250528	轴承套(长)(粉末冶金)	bushing	1
21	3012400400	250529-91	油封轴承	bearing	1
22					
23	30202004		后轴	shaft	1
24	31035002		手轮	pulley	1
25	S12001	4556	尖端紧定螺钉 M6×8	screw	1
26	S10009	4541	螺钉 M6×8	screw	1
27	301S10004		针杆曲柄螺钉		1

7

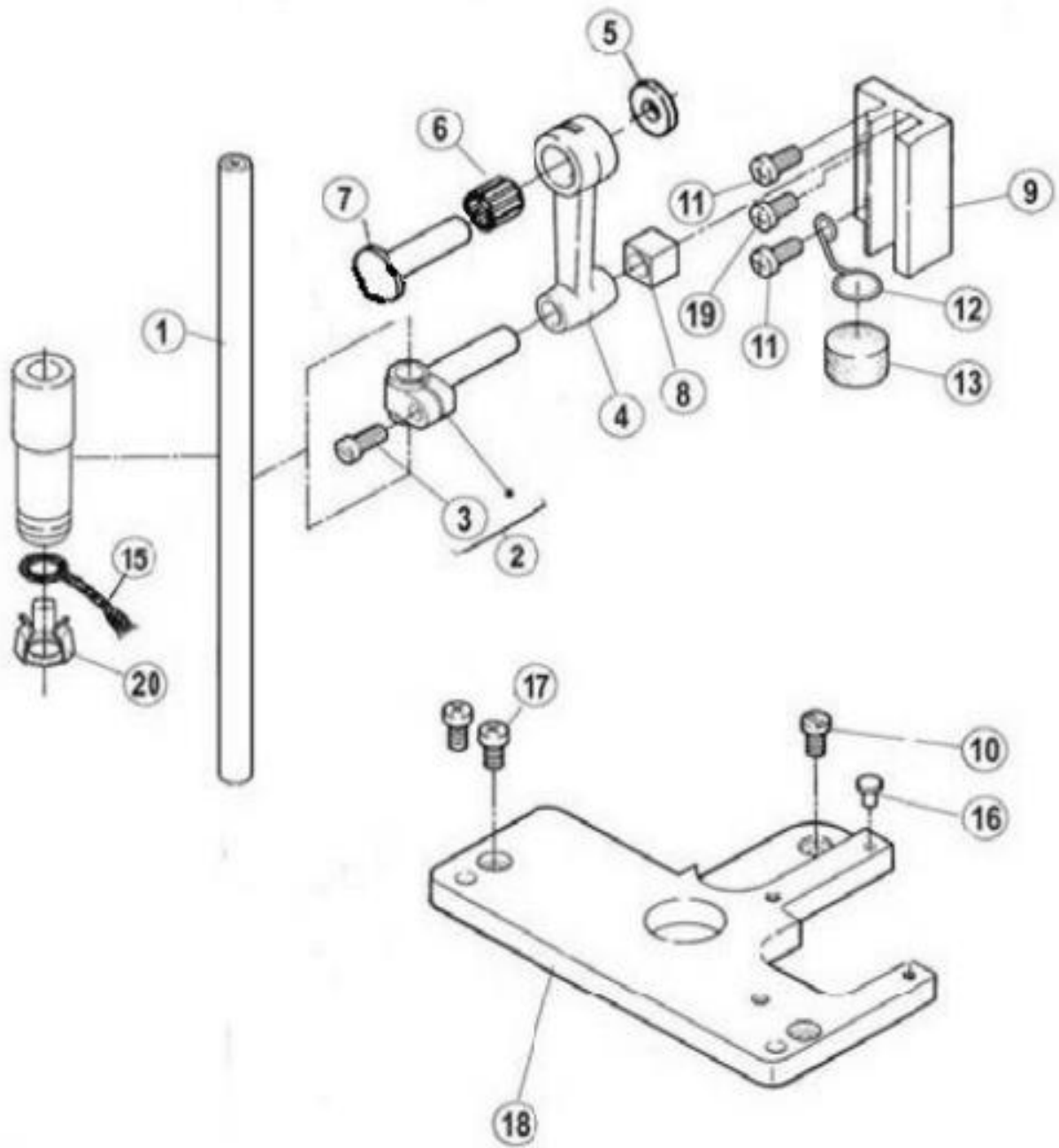

## 七、针杆部件(Needle bar assemblies)

序号Ref. No	公司件号 Part No	参考件号 Ref. Part.	名称	Description	数量Number
1	30102008	251000-91	针杆	needle bar	1
2	30102009	206061	针杆轧头	needle bar pin	1
3	301S11005	5325	针杆轧头螺钉	screw	1
4	30105005	206052	针杆连杆	link/needle bar drive	1
5	30128006	205097	针杆连杆轴垫圈	washer	1
6	B07001	240098	轴承 8×12×12	needle bearing	1
7	30102010	251010A	针杆连杆轴	eccentric pin	1
8	30109004	206063	针杆滑块	block	1
9	30109005	206062	滑块导座	guide block/needle	1
10	s01002	7082	螺钉 M4×6.5	screw	1
11	207S11008	7021	螺钉 M4×12	screw	2
12	30127003	251009	毛毡弹簧	spring	1
13	30123002	179040-05	毛毡	felt	1
15	30123014	202176	油线	oil wick	1
16	30122018	240123	防振垫	cushion rubber	1
17	301S17001	7019	针板螺钉(进口)	screw	2
18	30109006	251007	针板座	bracket	1
19	207S11007	7019	螺钉 M4×7.8	screw	1
20	30112009	206524	油线托	oil wick retainer	1

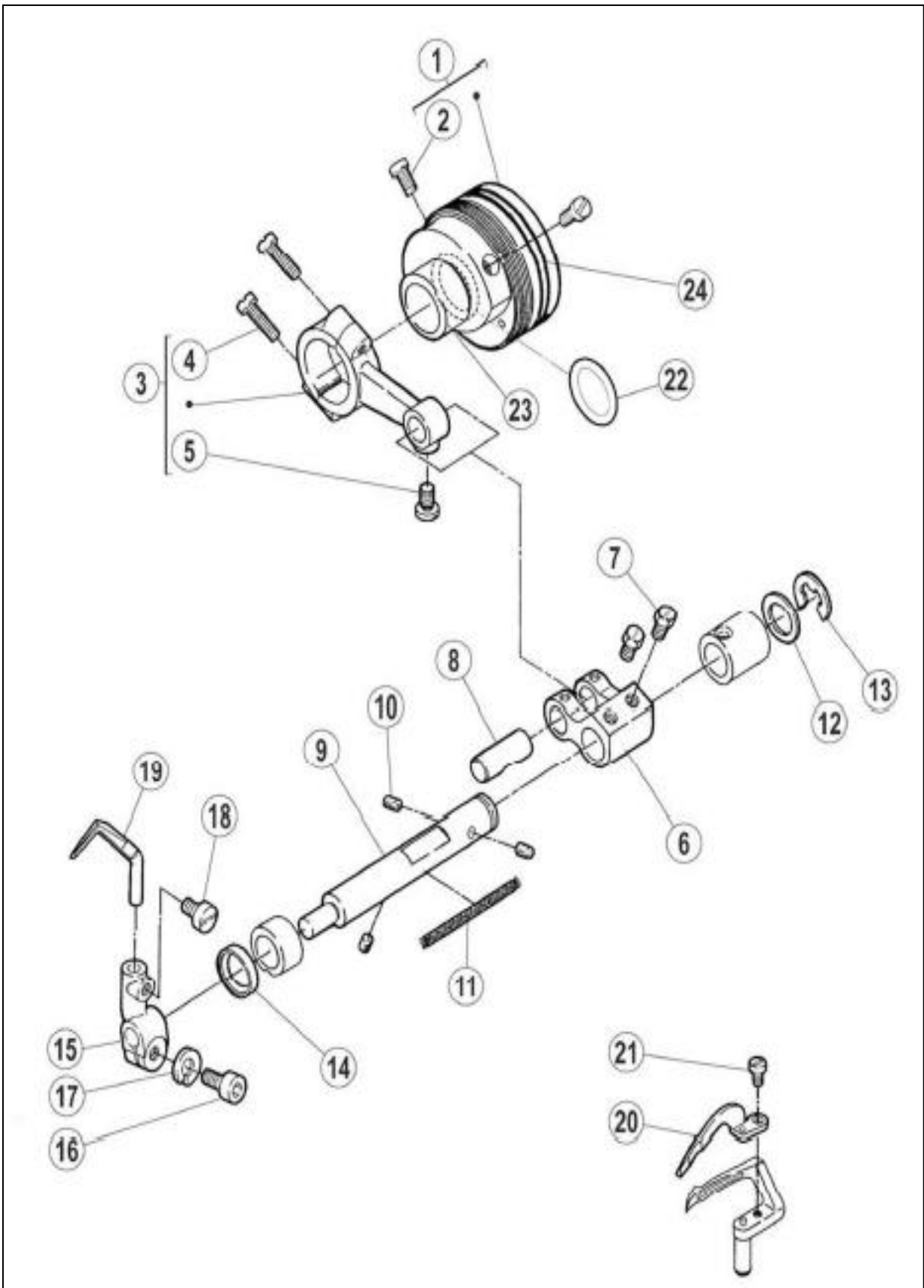

## 八、护针部件(Needle guard assemblies)

序号Ref. No	公司件号 Part No	参考件号 Ref. Part.	名称	Description	数量Number
1	B01001		轴承 6004Z	bearing	1
2	S10028	4539	螺钉 M5×6	screw	2
3	400062	255501-92	连杆组件	connection	1
4	S01039	7015	螺钉 M4×15	screw	2
5	301S11024	7082	滑块导座螺钉	screw	1
6	30104007	306093	弯针曲柄	crank	1
7	301S12001	5084	曲柄螺钉	screw	2
8	30126003	205495	曲柄销	pin	1
9	30102011	251518	护针轴	shaft	1
10	30123001	206748	毛毡	felt	3
11	30123014	202176	油线	oil wick	1
12	30128008	240102	护针轴垫圈	washer	1
13	H05001	205061	挡圈 10	ring	1
14	30122019	204052A	油封	oil seal	1
15	30104009	251519	护针挡架	lever assy	1
16	S05003	4500	螺钉M5×10	screw	1
17	W02001	303067	M5不锈钢弹垫	washer	1
18	S01002	7017	螺钉 M4×6.5	screw	1
19	30117002	257551B	后护针挡(JK)	needle guard (re)	1
20	30117003	257553	前护针挡	needle guard (fr)	1
21	S01012	7031	螺钉 M2.5×4	screw	1
22	001001		O型圈15×2.65	oring	1
23	30110002	251517	偏心凸轮	eccentric	1
24	30122017		油承槽油封	oil seal	2

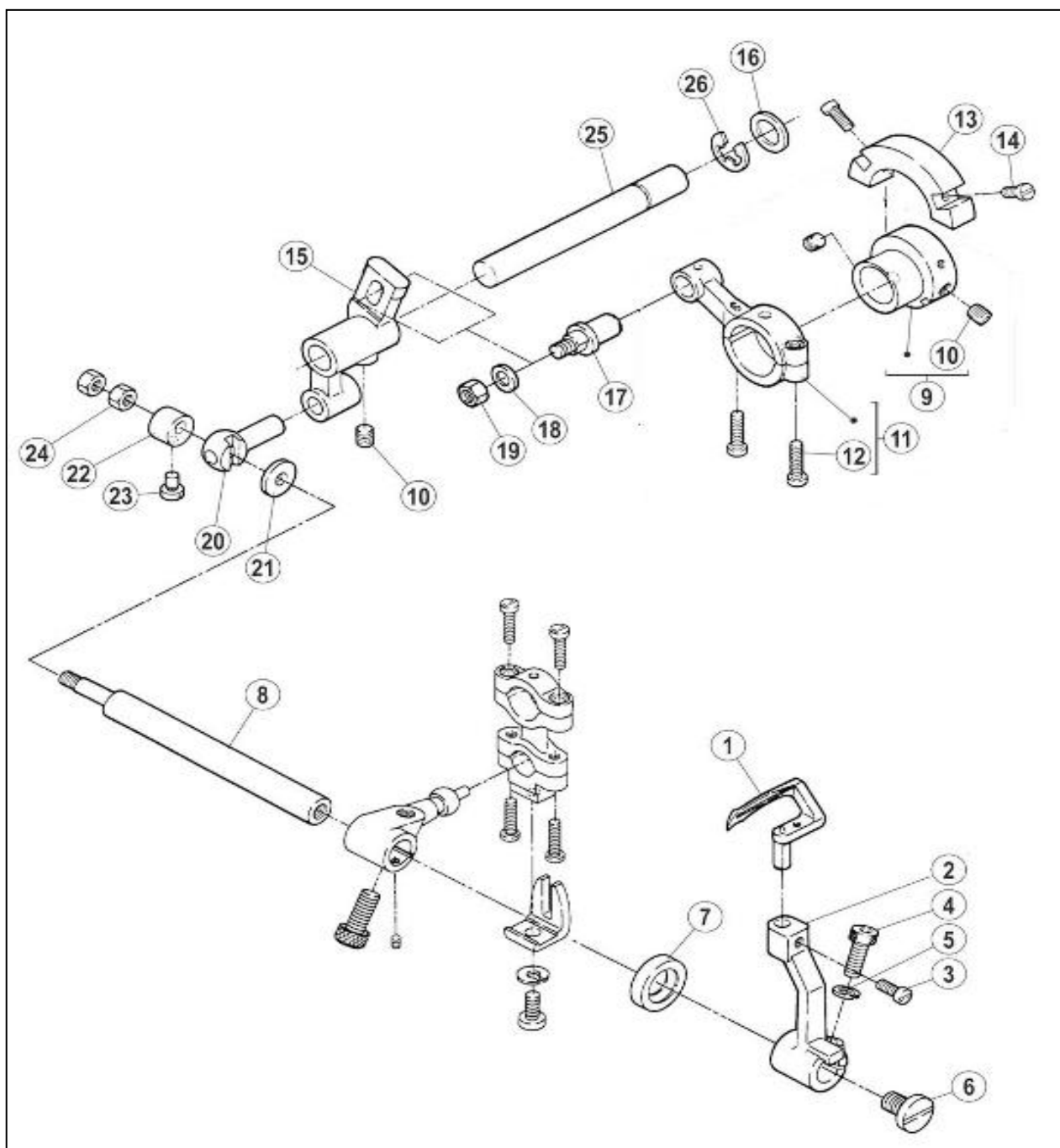

## 九、弯针部件(Looper assemblies)

序号Ref. No	公司件号 Part No	参考件号 Ref. Part.	名称	Description	数量 Number
1	3011700900	257550-91	弯针组	looper	1
2	30104012	252007	弯针架	looper holder assy	1
3	301S20038	7019	JK-8569A-W8-30圆 柱头凹端螺钉	screw	1
4	S05004	4501	螺钉 M5×14	screw	1
5	W02001	303067	M5不锈钢弹垫	spring washer	1
6	S01014	7085	螺钉 M6×0.75×9.6	screw	1
7	20622019		油封	oil seal	1
8	30102014	252006	弯针架轴	shaft	1
9	30110005	252000	摆架偏心轮	eccentric assy	1
10	S10006	4539	螺钉 M5×6	screw	1
11	400063	252001-92	连杆组件	connection	1
12	(S01039)	7015	螺钉 M4×15	screw	2
13	31109001	252010	平衡块	balance weight	1
14	S01009	7011	螺钉 M3×7.5	screw	2
15	30104010	252002	弯针摆动架	crank	1
16	30128008	240102	摆架轴垫圈	washer	1
17	30102013	179399-05	连杆轴	pin	1
18	30128032	240062	垫片	washer	1
19	N01004	4805	螺母 M5	nut	1
20	30102015	252003	摆轴轧头	block pin	1
21	30128010	208028	垫圈	washer	1
22	30108002	208029	偏心挡圈	collar	1
23	301S12001	5084	曲柄螺钉	screw	1
24	N01001	4802	螺母 M4	nut	2
25	30102012	252004	摆架轴	shaft	1
26	H05001	205061	挡圈 10	ring	1

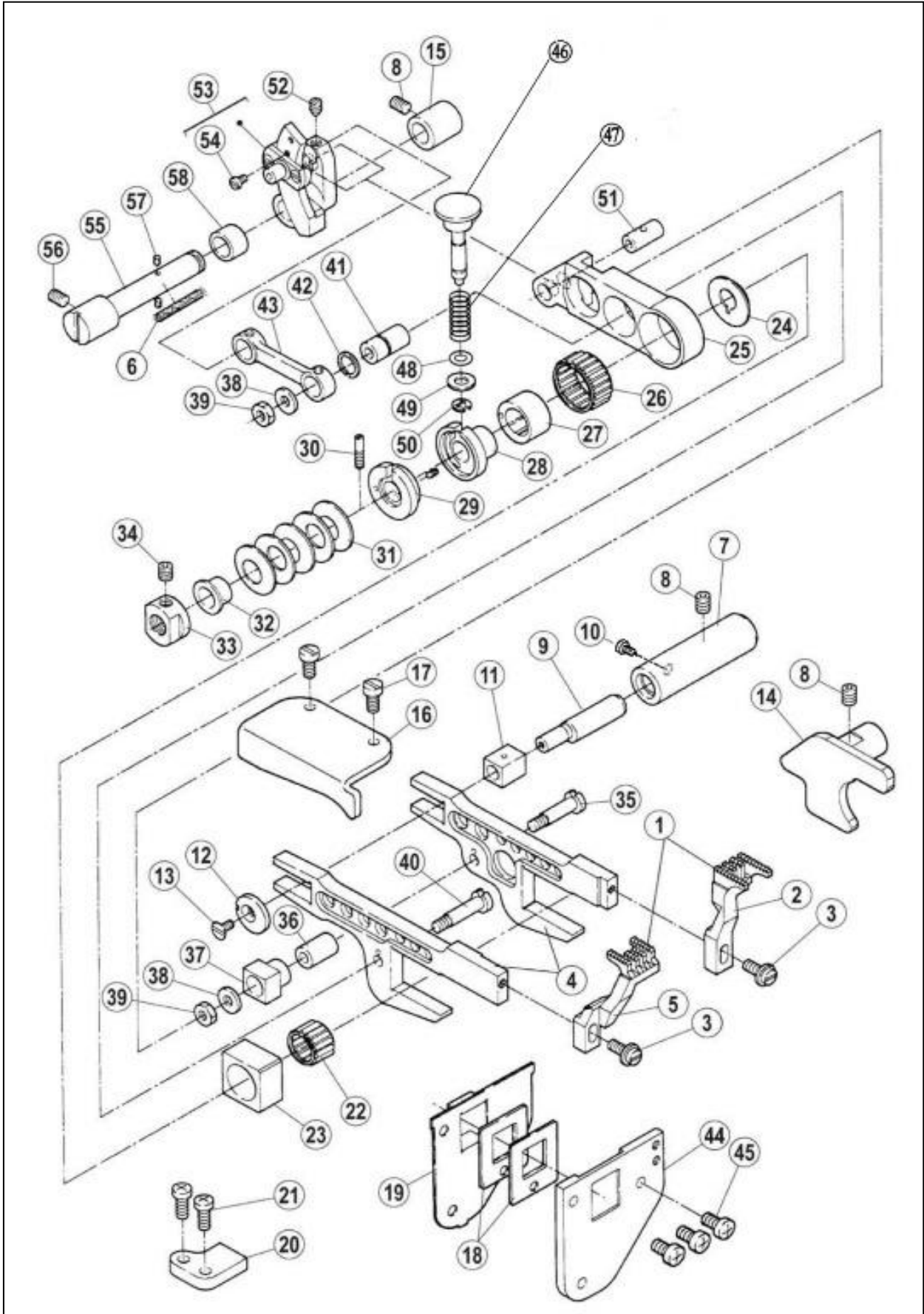

## 十、牙架部件(Feed dog holder assemblies)

序号 Ref. No	公司件号 No	Part	参考件号 Ref. Part.	名称	Description	数量 Number
1	3011400700		257259-16F	差动送布牙组件	main feed dog assembly	1
	3011400200		23GBL专用件			
	3011400300		23BBL专用件			
2	30114001			356、364送布牙	main feed dog	1
3	301S30003		5590	差动送布牙螺钉	screw	2
4	400066		252500-91	差动送布牙架组件	main feed bar assembly	1
5	30114002			356、364差动牙	differntial feed dog	1
6	20123021		202175	油线	oil wick	1
7	30103022		204129A	套筒	bushing	1
8	S10006		4539	螺钉 M5×6	screw	3
9	30102016		204128A	偏心轴	eccentric pin	1
10	301S12001		5084	曲柄螺钉	screw	1
11	30109008		205857	滑块	block/feed bar guide	1
12	30128011		204439A	偏心垫	washer	1
13	301S17002		5317	偏心轴螺钉	screw	1
14	30109009		252504	牙架挡板	guide(right)	1
15	30103031		206571	差动轴后套筒	bushing	1
16	30109010		252507	左挡板	guide(left)	1
	30109025		23机型			
17	L02003		7019	螺栓 M4×7	screw	2
18	30122020		206133	牙架油封	oilshield	2
19	30109011		252509	油封挡板	cover	1
20	30109012		252508	挡板	guide(lower)	1
	30109026		23机型			
21	S01005		7020	螺钉 M4×10	screw	2
22	B07002		206128	轴承 12×15×10	needle bearing	1
23	30109013		252519	抬牙滑块	block	1
24	30108003		252520	轴承挡圈	washer	1
25	30104013		206562	差动送布架	link/main feed	1
	30104049		23机型			
26	B07003		206125	轴承 17×21×10	needle bearing	1
	B07043		23机型			
27	30103023		252521	偏心轴承套	eccentric	1
	30103087		23机型			
28	30103024		252522	送布调节器	regulator	1
	3010308900		23机型			
29	3010306500		252523-91	调节器套组	eccentric retainer	1
	30103088		23机型			
30	301S30004		252516	调节器螺钉	screw	1
31	30128012		240125	碟形垫圈	spring	5
32	30103026		252525	垫圈套	spacer	1

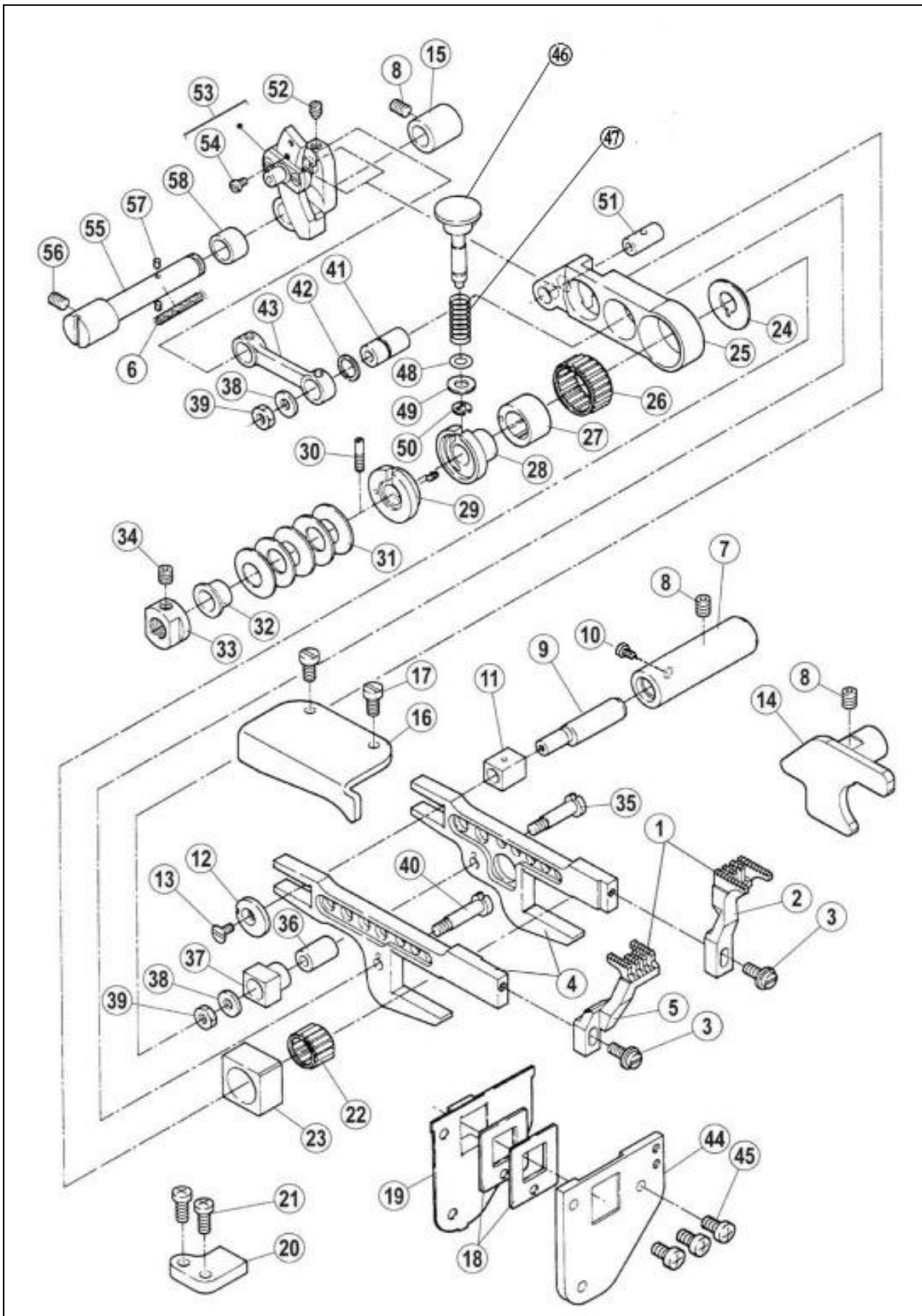

## 十、牙架部件(Feed dog holder assemblies)

序号 Ref. No	公司件号 No	Part	参考件号 Ref. Part.	名称	Description	数量 Number
33	301S16001		252543	调节螺母	nut	1
34	S10002		4514	螺钉 M5×5	screw	1
35	301S30005		206120	牙架螺钉	screw	1
36	30103027		206119	差动牙架套	bushing	1
37	30109014		206563	送布滑块	guide block	1
38	30128013		200098	垫片	washer	2
39	201S16003			N03 螺母	nut	2
40	301S30006		206123	差动牙架螺钉	screw	1
41	30103028		206566	差动连杆套	bushing	1
42	30129001		206565	开口挡圈	ring	1
43	30105010		206564	差动送布连杆	link/different al feed	1
44	30109015		251520	牙架挡板	bracket	1
45	207S11007		7019	螺钉 M4×7.8	screw	3
46	30102017		252526	针距调节按扭	pin	1
	(30126016)23机					
47	30127004		240122	针距调节簧	spring	1
	30127026					
48	001004		206366	O型圈 4×1.8	o ring	1
49	30128032		204585	垫圈	washer	1
	(12928008) 23 机型					
50	H05002		200555	挡圈 3	ring	1
51	30103029		206569	差动送布架套	pin	1
52	S12005		4546	螺钉 M4×4	screw	1
53	3010401500		252527-91	差动调整架组件	crank	1
54	(S01012)		7031	螺钉 M2.5×4	screw	1
55	30102018		252510	差动轴	shaft	1
56	S10002		4514	螺钉 M5×5	screw	1
57	30123008		207925	喂针轴油孔毛毡	felt	2
58	30103030		240119	差动轴前套筒	spacer	1

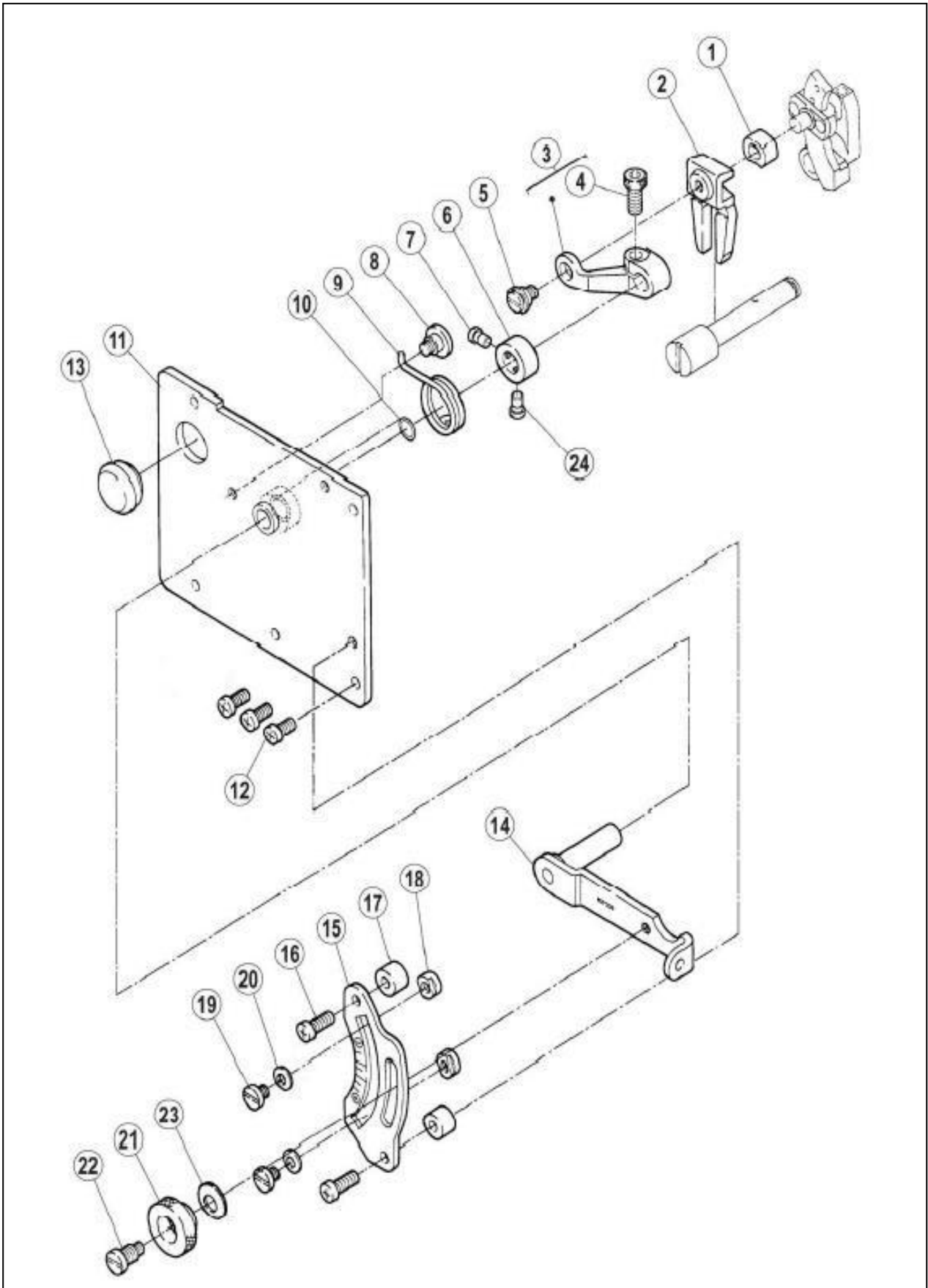

## 十一、 差动部件(Differential assemblies)

序号 Ref.No	公司件号 No	Part	参考件号 Ref. Part.	名称	Description	数量 Number
1	30103032		252531	方套	block	1
2	30109016		252532	比叉	guide/block	1
3	30105012		252533	连杆	lever	1
4	S05005		4531	螺钉 M5×12	screw	1
5	301S20006		5316	连杆连接螺钉	screw	1
6	30108004		240271	挡圈	ring	1
7	301S11007		35827	挡圈螺钉	screw	1
8	301S20001		7066	护罩座固定螺钉	screw	1
9	30127005		252536	弹簧	spring	1
10	001005		240129	O型圈 7.5×1.8	o ring	1
11	3011201100		252539A91	左板组件	bracket	1
12	207S11007		7019	螺钉 M4×7.5	screw	3
13	30122021		240162	油封堵	plug	1
14	3011201300		252664-91	调节扳手组件	lever assy	1
15	30112015		252538	调节板	scale plate	1
	30112220		23机型	调节板		
16	207S11008		7021	螺钉 M4×12	screw	2
17	31103003		240124	调节套	spacer	2
18	20109005		210171	调节滑块	stopper	2
19	301S11008		2905	螺钉	screw	2
20	W01006		201185	垫圈 4	washer	2
21	301S16004		210167	螺母	nut	1
22	301S30007		5486	调节扳手螺钉	screw	1
23	30128014		211301	垫圈	washer	1
24	301S11023			挡圈螺钉 (短)	screw	1

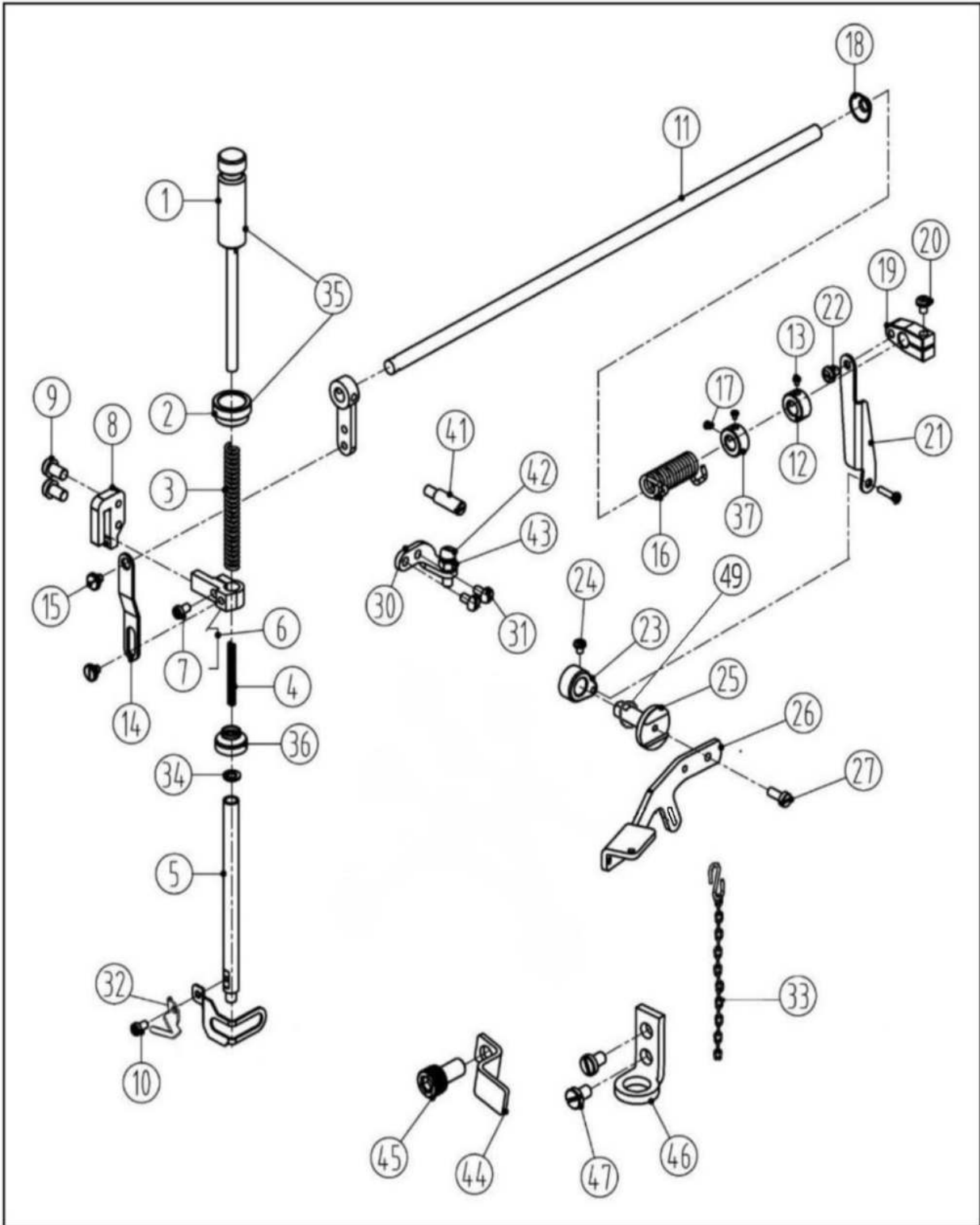

## 十二、压脚部件(Presser form assemblies)

序号 Ref. No	公司件号 No	Part	参考件号 Ref. Part.	名称	Description	数量 Number
1	(310S30002)		253000-91	调压螺杆	adjusting bar	1
2	(301S16005)		253003	调压母	nut	1
3	30127006		240252	调压簧	spring	1
4	30127008		240253	压脚轴小弹簧	spring	1
5	30102020		253026	压脚轴	presser bar	1
6	30104017		206139	压脚轧头	presser bar clamp	1
7	301S11009			螺钉M4×12	screw	1
8	3010901700		253005-91	导块销簧组件	guide	1
9	S11025		7025	螺钉M4×20	screw	2
10	S01006		7009	螺钉M3×4.5	screw	1
11	3010206400		263008-91	抬压轴	lever	1
12	30108006		192024	挡圈	collar	1
13	301S12001		5084	曲柄螺钉	screw	1
14	30112016		206157	压脚轧头连接板	link	1
15	301S20007		5386	螺钉	screw	2
16	30127009		253010	抬压轴簧	spring	1
17	301S12001		206156	曲柄螺钉	collar	2
18	30122023			油封	plug	1
19	30104019		206149	抬压曲柄I	bell crank(upper)	1
20	301S11011		5187	抬压曲柄螺钉	screw	1
21	30212018		253027	抬压曲柄连接板	link	1
22	301S20008		5184	连接板螺钉	screw	2
23	30104020		206148	抬压曲柄II	bell crank(lower)	1
24	301S20013		002022-4	抬压曲柄II固定螺钉	screw	1
25	31002006			抬压轴	shaft	1
26	131412003			压脚扳手(D)	lever	1
27	S01011			螺钉	screw	1
30	31012110			K4-1148压脚限位板	link	1
31	S01004			螺钉	screw	2
32	30119020			线辫割刀		
33	30131018			链条	screw	1
34	O01006		240095	O型圈8.5×1.8	o ring	1
35	3100201000			K4-1125调压螺杆组件	adjusting bar assembly	1
36	30722004			JK-8670-1106橡皮塞	oil guard.	1
37	30108005		253028	JK-8568-W11-22挡圈	finger guard	1
41	310S20014			K4-1150限位螺钉	screw	1
42	S01016			螺钉 M5×17	pulling plate	1
43	N01004			螺母M5	clamp	1
44	31012091			K4-1138线卡	screw	1
45	S05003			螺钉 M5×10 8.8级 镀白	Support plate	1
46	31112005			W4-1201链条挡板	stator	1
47	207S11007		7017	螺钉 M4×7.5	screw	2
48	30112017			JK-8569-W11-14压脚护罩		1
49	20122038			O型圈		1

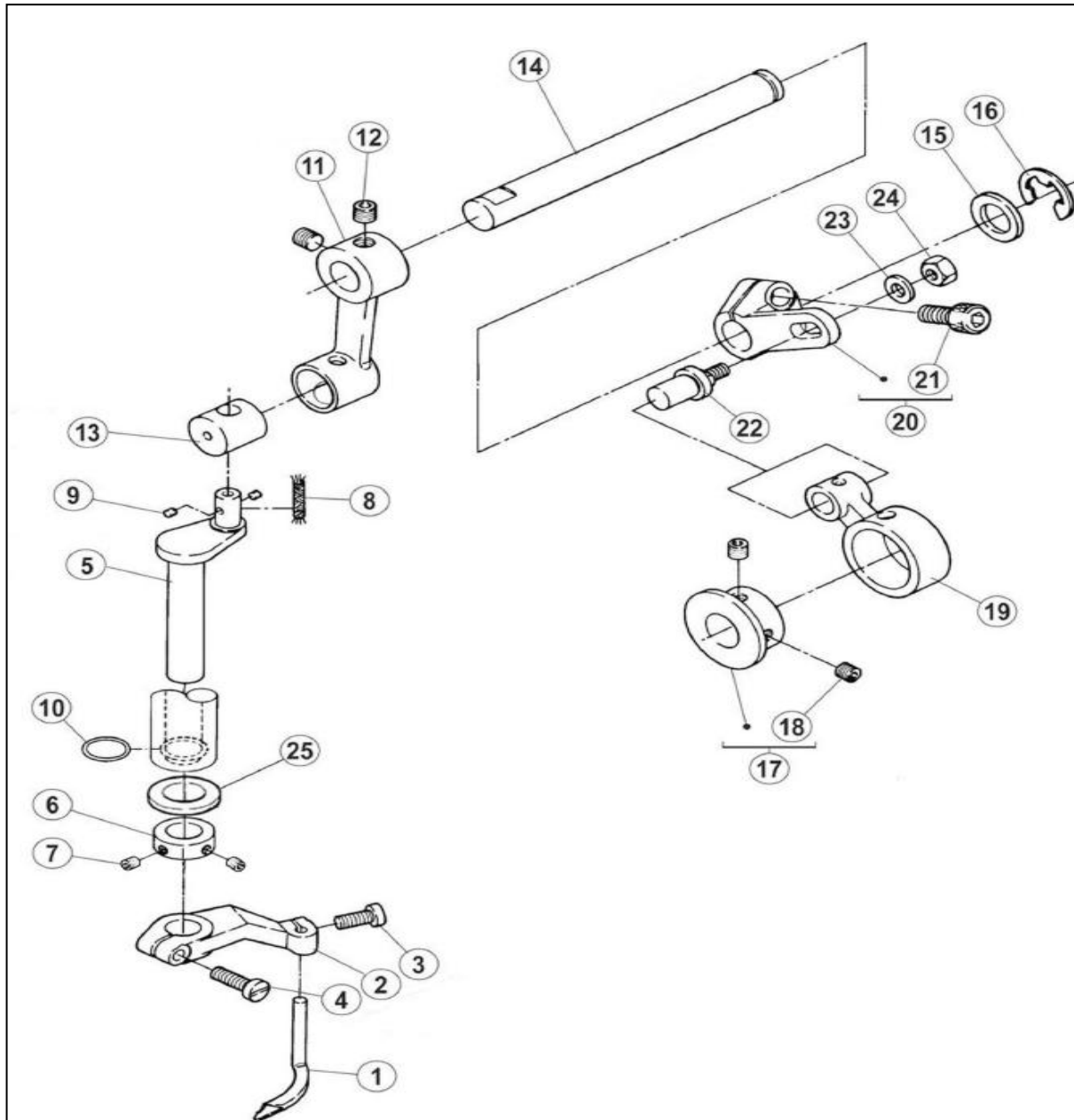

### 十三、 喂针部件(Needle feeding assemblies)

序号Ref. No	公司件号 Part No	参考件号 Ref. Part.	名称	Description	数量 Number
1	30117005	257565	喂针	spreader	1
2	30104022	254516	喂针架	lever/assy	1
3	S01005	7020	螺钉 M4×10	screw	1
4	S01017	7022	螺钉 M4×14	screw	1
5	30102023	254508	摆动轴	crankshaft	1
6	30208010	212039	喂针轴挡圈	collar	1
7	S10005	S071	挡圈螺钉M3×3	screw	2
8	20123021	202176	油线	oil wick	1
9	30123008	207925	摆动轴油孔毛毡	felt	2
10	(001008)	233020	O型圈 9×1.8	o ring	1
11	30105013	254506	喂针摆动连杆	crank	1
12	S10029	4547	螺钉 M6×0.75×5	screw	2
13	30126005	254507	喂针摆动销	block	1
14	30102024	254519	摆动连杆轴	shaft	1
15	30128015	206180	摆动连杆轴垫圈	washer	1
16	H05004	306671	挡圈12	ring	1
17	30110007	254501A	喂针凸轮	eccentric assy	1
18	S10002	4514	螺钉 M5×5	screw	2
19	400059	254511	喂针连杆	connection	1
20	30104024	254503	喂针摆动曲柄	crank	1
21	S05002	4534	螺钉 M6×0.75×15.2	screw	1
22	30126006	254504	连杆销	screw	1
23	30128032	240062	垫圈	washer	1
24	N01004	4805	螺母 M5	nut	1
25	30128018		垫圈	washer	1

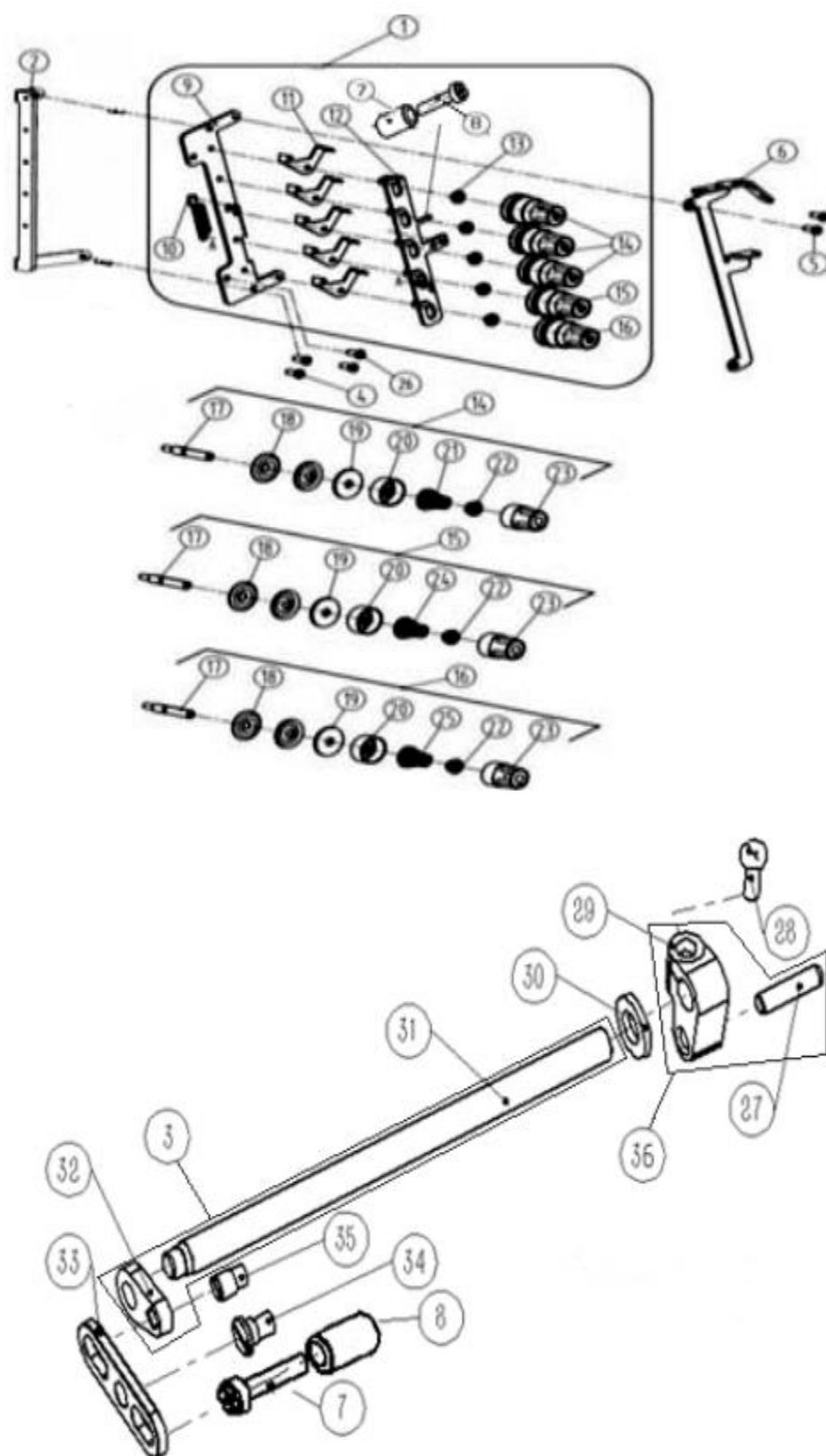

#### 十四、 松线部件(Thread loosing assemblies)

序号Ref. No	公司件号 Part No	参考件号 Ref. Part.	名称	Description	数量 Number
1	13141300100	201068	夹线器	tension	1
2	131113002		松线架	loose thread stand	1
3	31009004		松线垫块	block	2
4	S04019		螺钉M4×12	screw	2
5	S04010		螺钉M4×5.5	screw	2
6	S04020		螺钉	loose line board	1
7	31003005		轴套	screw	1
8	N01004		螺母M5	Nut	1
9	131113001		钢丝支撑架	loose line board	1
10	30127010		调节板簧	reset spring	1
11	30113007		二孔过线板	thread guide	5
12	31013008		松线板	loose line board	1
13	30103041	206202	调节套	spacer	5
14	131113006	254010A9U	调线组件（强）	tension spring assembly (heavy)	3
15	131113007	254010B9U	调线组件（中）	tension spring assembly	1
16	131113008	254010C9U	调线组件（弱）	tension spring assembly (light)	1
17	301S30010	001817-2A	夹线延	screw stud	1
18	30128016	210319	夹线片	tension disc	2
19	20623008		松线夹线片垫	felt	1
20	21111099	208450-UA	调压止动盖	cup	1
21	30127011	301037	调压簧（强）	spring (heavy)	3
22	30111006	208448	调压止动套	ratchet	1
23	21111098	208447-UA	调压螺母	nut 3	1
24	30127012	201086	调压簧（中）	spring (medium)	1
25	30127013	201068	调压簧（弱）	spring (light)	1
26	207S11007		螺钉 M4×7.8	screw	2
27	30126007		松线曲柄定位销	screw	2
28	S05005		螺钉M5×12	screw	1
29	30104026		松线曲柄	crank	1
30	W01010		平垫圈	washer	1
31	131104001		松线曲柄	shaft	1
32	30512034		连接板M5	thread	1
33	131412004		转接板	thread	1
34	423S20004		轴位螺钉	screw	1
35	301S20030		螺钉	screw	1
36	3010403100		松线曲柄I组件		1

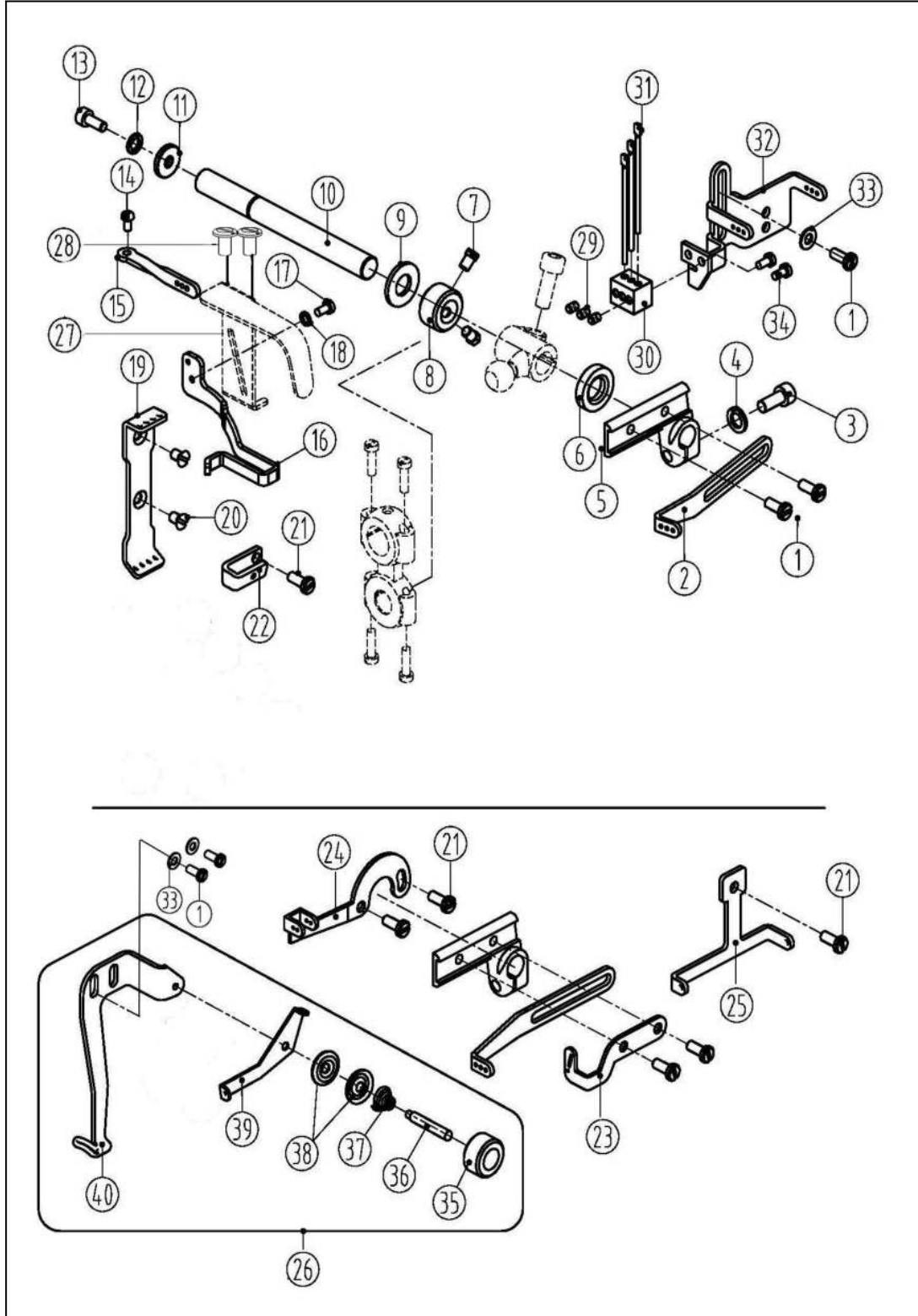

## 十五、 过线部件(Thread loosing assemblies)

序号 Ref.No	公司件号 Part No	参考件号 Ref. Part.	名称	Description	数量 Number
1	S01001	7019	螺钉M4×7	screw	6
2	31013006	253505A	长过线板	thread take-up	1
3	S05004	4501	螺钉M5X14	screw	1
4	W02001	303067	垫圈	washer	1
5	30101018	253504	过线座	lever	1
6	20622019		油封	plug	1
7	301S12001	5084	曲柄螺钉	screw	2
8	30108008	240201	过线座轴挡圈	ring	1
9	30128008		摆架轴垫圈	washer	1
10	31002001	253503	过线座轴（中轴）	shaft	1
11	30128019	204107	垫片	washer	1
12	W02002	201252	M4垫圈	washer	1
13	S05048	4527	螺钉M4X10	screw	1
14	311S05001	7009	针杆螺钉	screw	1
15	31013017	253507	三孔过线	thread guide	1
16	131412002		护线罩	thread support	1
17	S01006		螺钉	screw	1
18	30128034		垫圈	washer	1
19	31013005		过线板	thread guide	1
20	206S30016	7170	螺钉	screw	2
21	207S11007	7018	螺钉M4×7.8	screw	3
22	31012045		U型夹线座	thread tension bracket	1
23	31012018		过线板	thread guide	1
24	30112029	253514	喂针过线	thread guide	1
25	31013011	253515	过线板	thread guide	1
26	3011203200		喂针过线组件	thread guide	1
27	131412001		针杆护罩		1
28	207S11007		针杆护罩螺钉		2
29	S10001	4535	螺钉M3×4	screw	3
30	30113012	253545	针杆过线座	holder	1
31	30113013	234521	过线杆	thread guide	3
32	30112027	253544	硅油合固定架	thread guide	1
33	W01001	303448	M4垫垫片	washer	3
34	S01006	7009	螺钉M3×4.5	screw	2
35	1311NS16002		调压螺母	adjusting nut	1
36	(301S30055)		调线螺钉	adjusting	1
37	12927012	137109	夹线簧	spring	1
38	12928036	137108	夹线片	thread	2
39	30112032	253547	喂针二眼过线	thread guide	1
40	31112008	253548	喂针过线板	thread guide	1

# 16

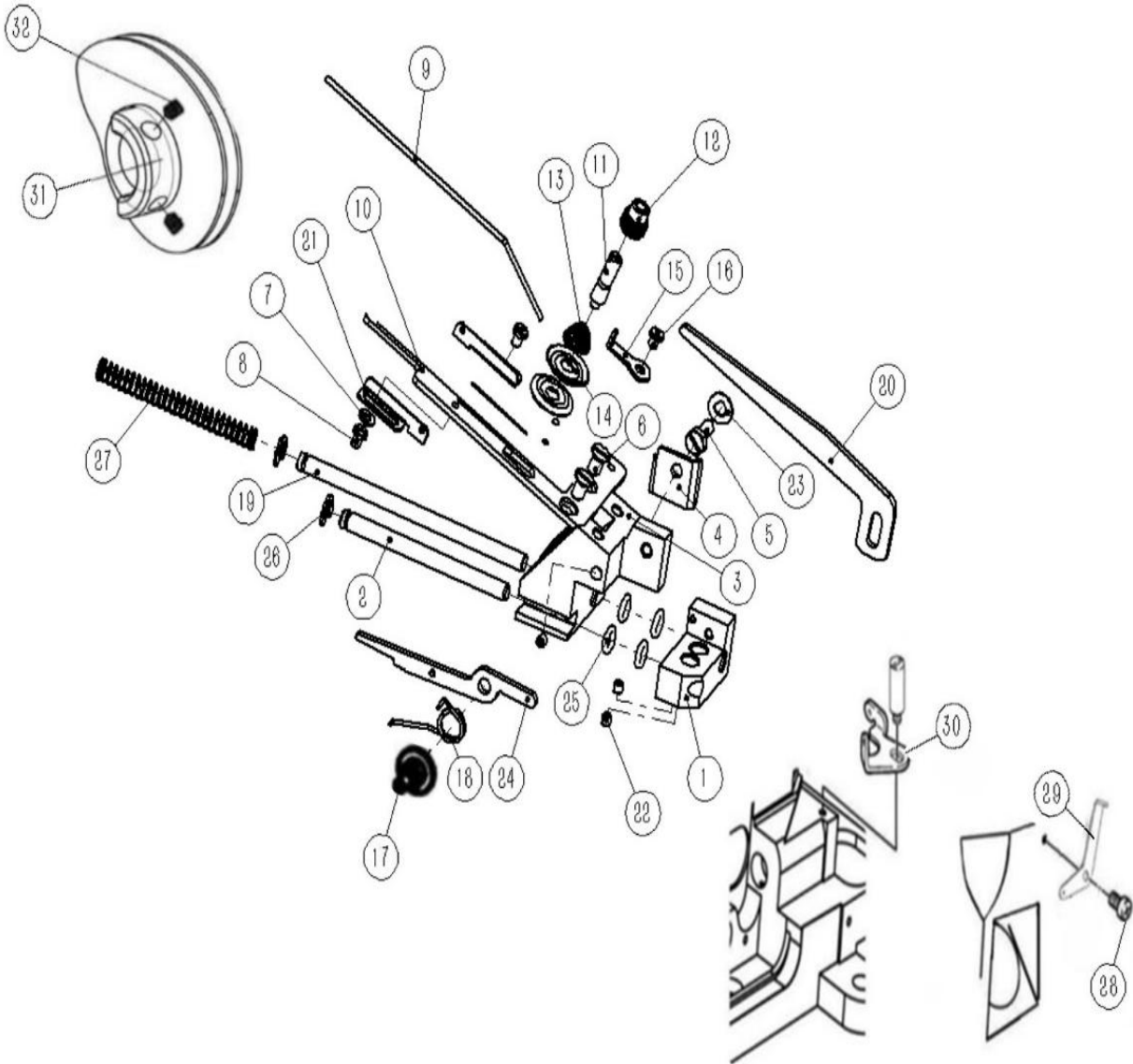

## 十六、 打线凸轮内置部件(Inside cam assemblies)

序号Ref. No	公司件号 Part No	参考件号 Ref. Part.	名称	Description	数量 Number
1	30101020		滑杆座	bracket	1
2	30102030		短滑杆轴	shaft	1
3	30101019		打线座架	bracket	1
4	131312009		挡板	ring	1
5	L02002		开槽六角螺钉 M4×10	screw	1
6	S02003		开槽沉头螺钉	screw	1
7	W01012		平垫圈2.5	ring	1
8	S01012		开槽圆柱头螺钉 M2.5×4	screw	1
9	30112036		挡线杆	shaft	2
10	30112035		打线架	bracket	1
11	301S30011		调压螺钉	screw	2
12	1311NS16002		自锁调压螺母	tension nut	1
13	30127016		夹线簧	spring	1
14	12928036		小夹线片	thread guide	1
15	30113015		过线片	thread guide	1
16	402S11016		一字螺钉 SM1/8"×44×3.4	screw	1
17	301S20010		轴位螺钉M3	screw	1
18	30127018		弹簧	spring	1
19	30102029		长滑杆轴	shaft	1
20	30112037		打线片	thread guide	1
21	30113014		打线架过线	thread guide	1
22	S10005		内六角凹端紧定螺 钉M3×3	screw	1
23	W01001		平垫圈4	ring	2
24	30112038		扳手	ring	1
25	001009		O型橡胶密封圈 4.5×1.8	wrench	1
26	H05909		开口挡圈4	ring	2
27	30127017		弹簧	spring	1
28	S01001		螺钉M4×7	screw	1
29	30113016		过线	thread guide	1
30	30113045		过线	thread guide	1
31	30103071		打线凸轮组件	thread takeup	1
32	S10002		螺钉M5×5	screw	2

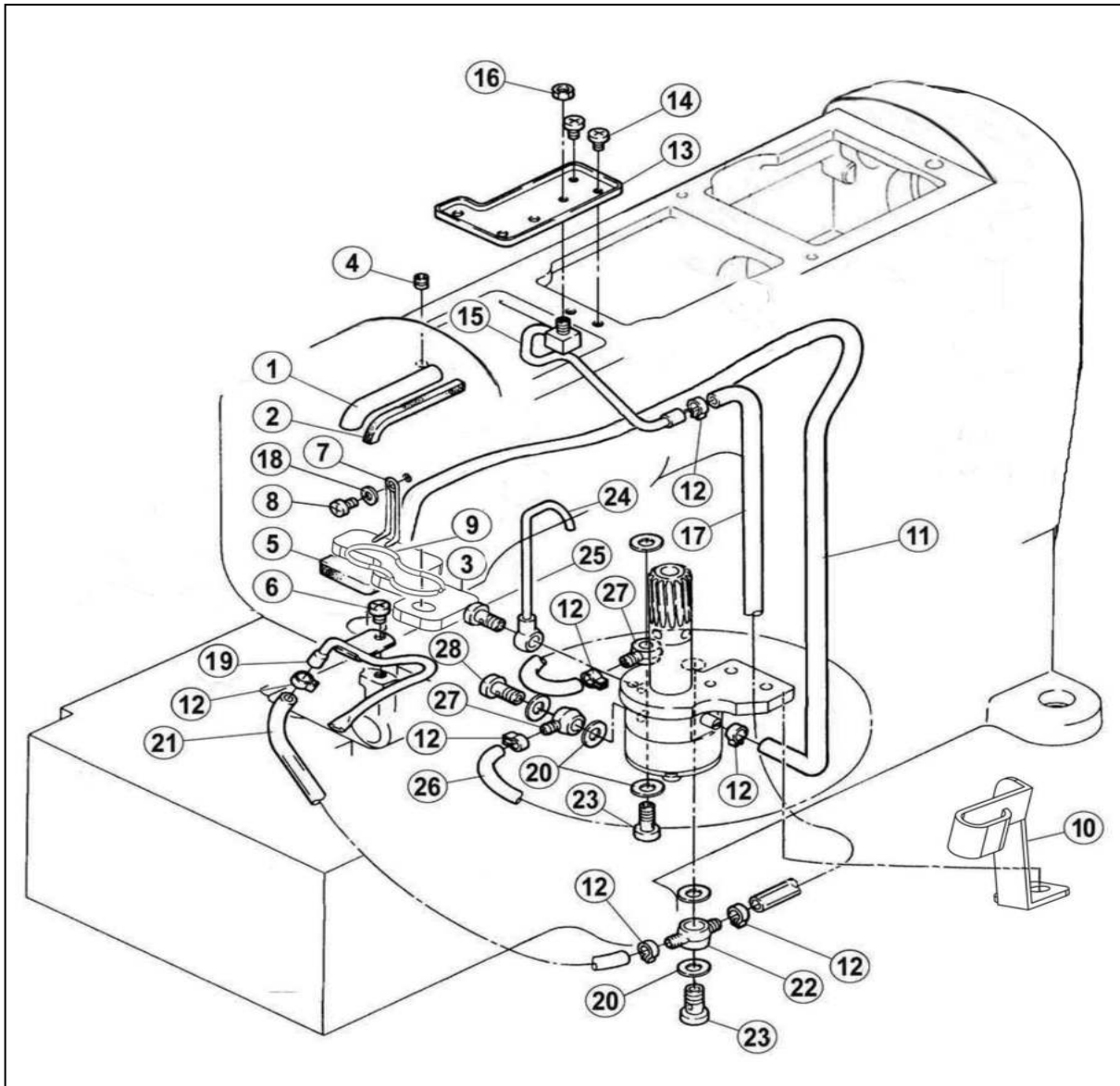

## 十七、润滑部件 (Lubrication assemblies)

序号Ref. No	公司件号 Part No	参考件号 Ref. Part.	名称	Description	数量 Number
1	30121012	255003	铜油管	oil pipe	1
2	30123010	240136	油毡	felt	1
3	30223023		针杆回油毡	felt	1
4	S10002	4514	螺钉 M5×5	screw	1
5	30223023	255021	油毡	felt	1
6	301S11024		滑块导座螺钉	screw	1
7	30127045	200136	回油毡卡簧	clamp	1
8	207S11007	255005	螺钉 M4×7.5	screw	1
9	30127060		毛毡卡簧		1
10	30112186		油管固定架	supporting structure	1
11	12921002	240135	维尼龙油管	tube	1
12	20429001	202199	油管卡簧	clamp	6
13	30112039	255006	接油盘	oil guard	1
14	S01002	7017	螺钉 M4×6.5	screw	2
15	3012101500	255007-91	喷油管组	oil	1
16	N01001	4821	螺母 M4	nut	1
17	30121022	240134	Φ4×Φ6油管	tube	1
18	W01001	303448	垫圈 4	ring	1
19	30121009	255010-91	喷油管	oil	1
20	20122033		垫片	washer	6
21	30121022	240134	Φ4×Φ6油管	tube	1
22	30136005	200136	油管接头	joint	1
23	301S30013	200152	过油螺钉	joint screw	2
24	30136003	255035-91	铜油管接头	pipe	1
25	301S30012	255037	油管螺钉	screw	1
26	30121022	240134	Φ4×Φ6油管	tube	1
27	30136005	200136	油管接头	joint	1
28	201S30004	200152	过油螺钉	joint screw	1
29	30129007		油管卡簧		1
30	20136007		油管接头塑料		2

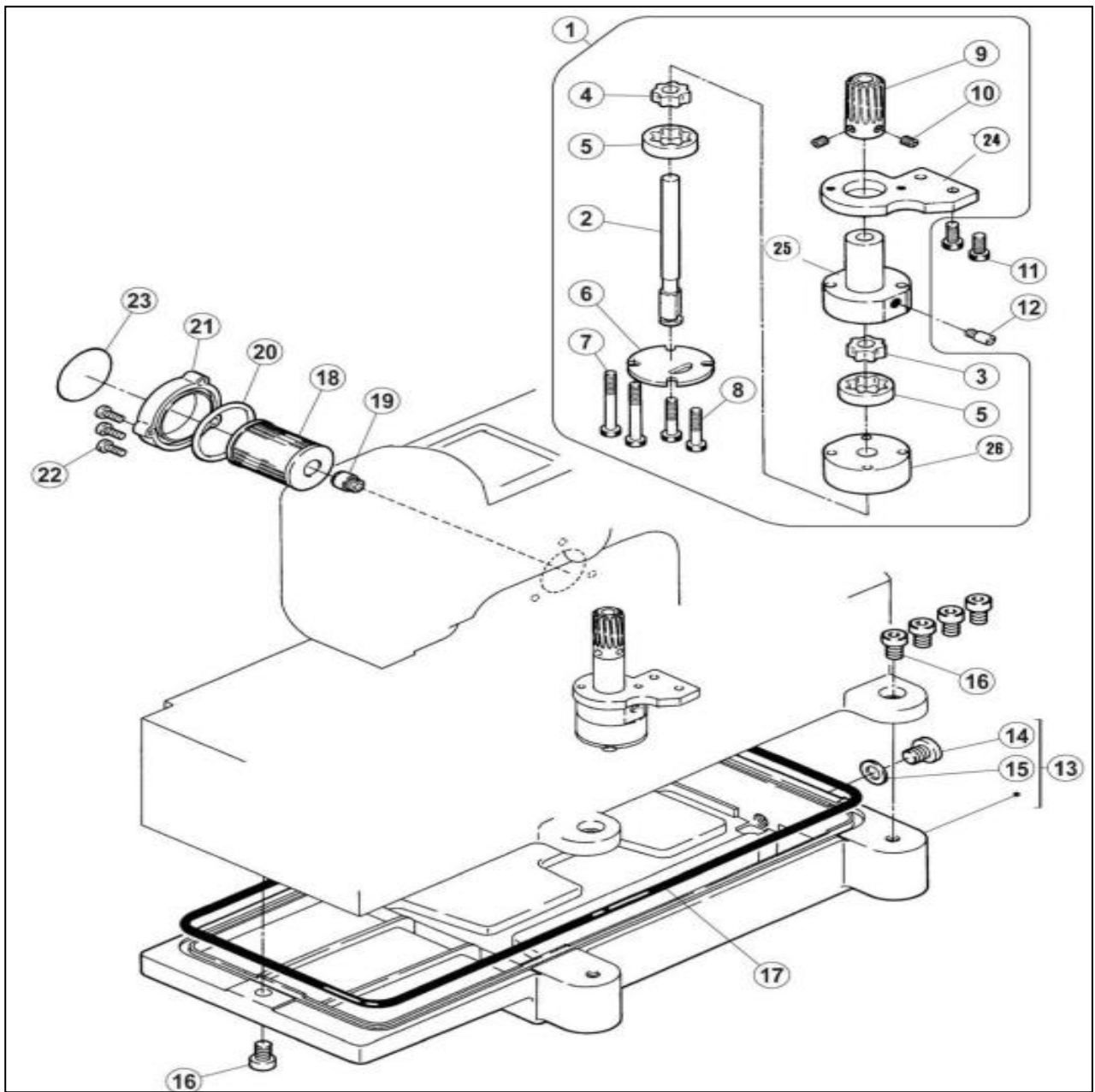

## 十八、 油泵部件(Oil pump assemblies)

序号Ref. No	公司件号 Part No	参考件号 Ref. Part.	名称	Description	数量Number
1	3012000100	255040-91	油泵组件	oil pump assy	1
2	30102031	255024	油泵轴	shaft	1
3	30120004	255025	主动轮2	rotor	1
4	30120007	255026	主动轮1	rotor	1
5	30120005	255027	从动轮	rotor	2
6	30120008	255028	油泵盖	cover	1
7	(301S20011)	7105	油泵螺钉	screw	2
8	(S05006)	7026	螺钉 M4×25	screw	2
9	30125003	255019	油泵蜗轮	worm wheel	1
10	(S10002)	4514	螺钉 M5×5	screw	2
11	S05005	4501	螺钉 M5×14	screw	2
12	301S30014		过油螺钉	joint screw	1
13	30101023	255000	油盘	oil reservoir	1
14	301S11015	5138B	堵油螺钉	screw	1
15	20528014	202287A	垫圈	washer	1
16	S05007	4504	螺钉 M8×20	screw	5
17	30122025	255001	油盘密封圈	o ring	1
18	20736004	206233	滤油器	filter element	1
19	201S30030	210200	滤油器接头	bracket/filter element	1
20	001010	206431	O型圈 38.7×3.55	o ring	1
21	930100036	210201-SD	滤油器盖	cover	1
22	207S11008	7021		screw	3
23	30131004	9A3002	提示说明	filter seal	1
24	30120002		油泵固定板	fixed plank	1

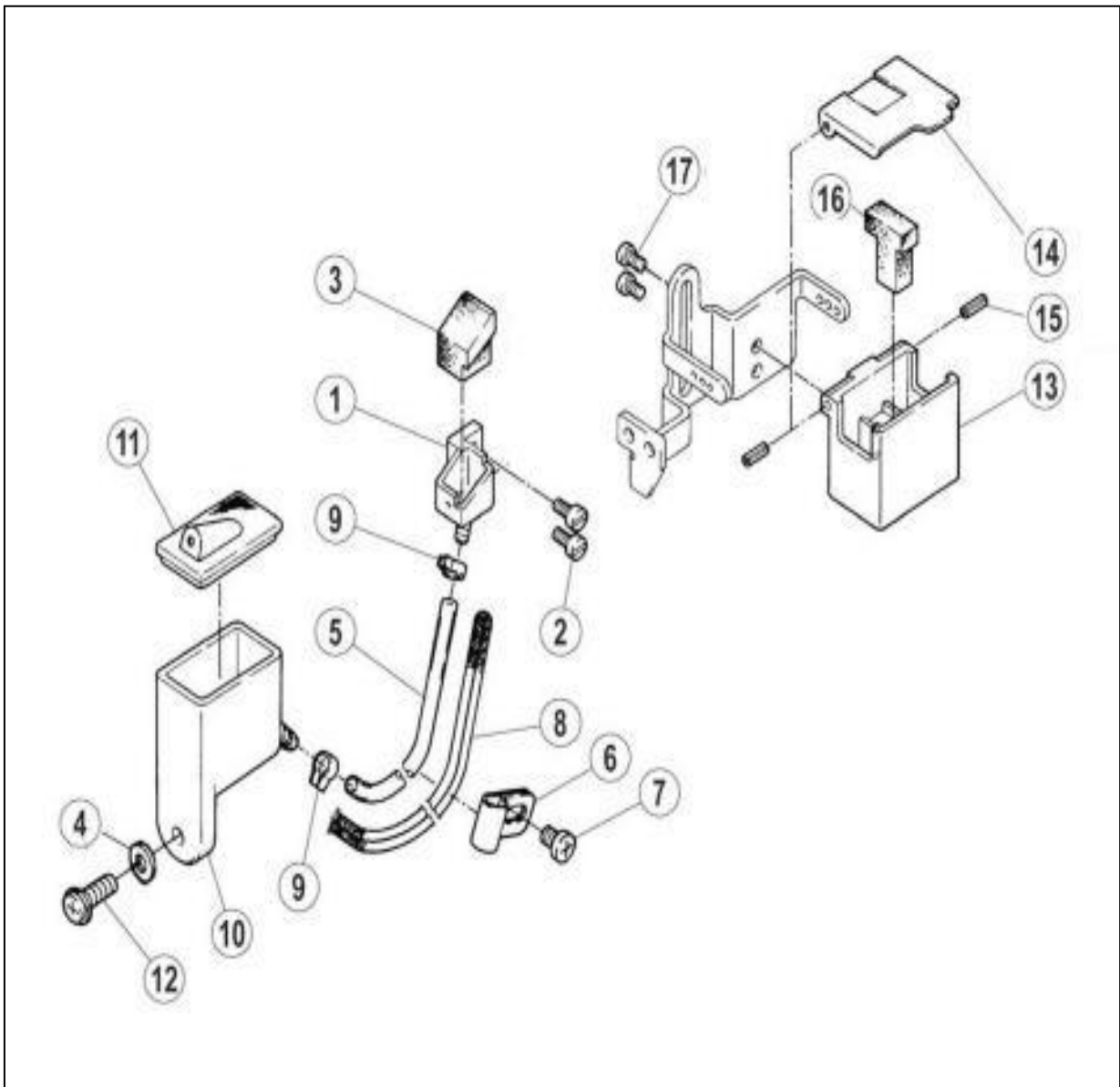

十九、硅油盒装置部件 (Silicon oil delice assemblies)

序号Ref. No	公司件号 Part No	参考件号 Ref. Part.	名称	Description	数量 Number
1	30101027	255013	机针冷却器	needle cooler (lower)	1
2	S01027	7010	螺钉 M3×6	screw	2
3	30123012	255014	油棉	felt	1
4	W01001	303448	垫圈 4	washer	1
5	30121021	240117	Φ5×Φ7油管	tube	1
6	30127020	206115	油管压簧片	bracket	1
7	S01002	7019	螺钉 M4×6.5	screw	1
8	20123021	202175	油线	oil wick	1
9	20429001	202199	油管卡簧 (小)	clamp	2
10	30101026	255015	下硅油盒	silicone oil reservoir (lower)	1
11	30122026	255016	下硅油盒盖	cap	1
12	S01005	7020	螺钉 M4×10	screw	1
13	30111070	207066-UD	上硅油盒 (塑料)	silicone oil reservoir (upper)	1
14	30112040	207067-UD	硅油盒盖	cap	1
15	P03008	206781	销 2×6	pin	2
16	30123011	207068	硅油棉	felt	1
17	S16002	7009	螺钉 M3×4.5	screw	2

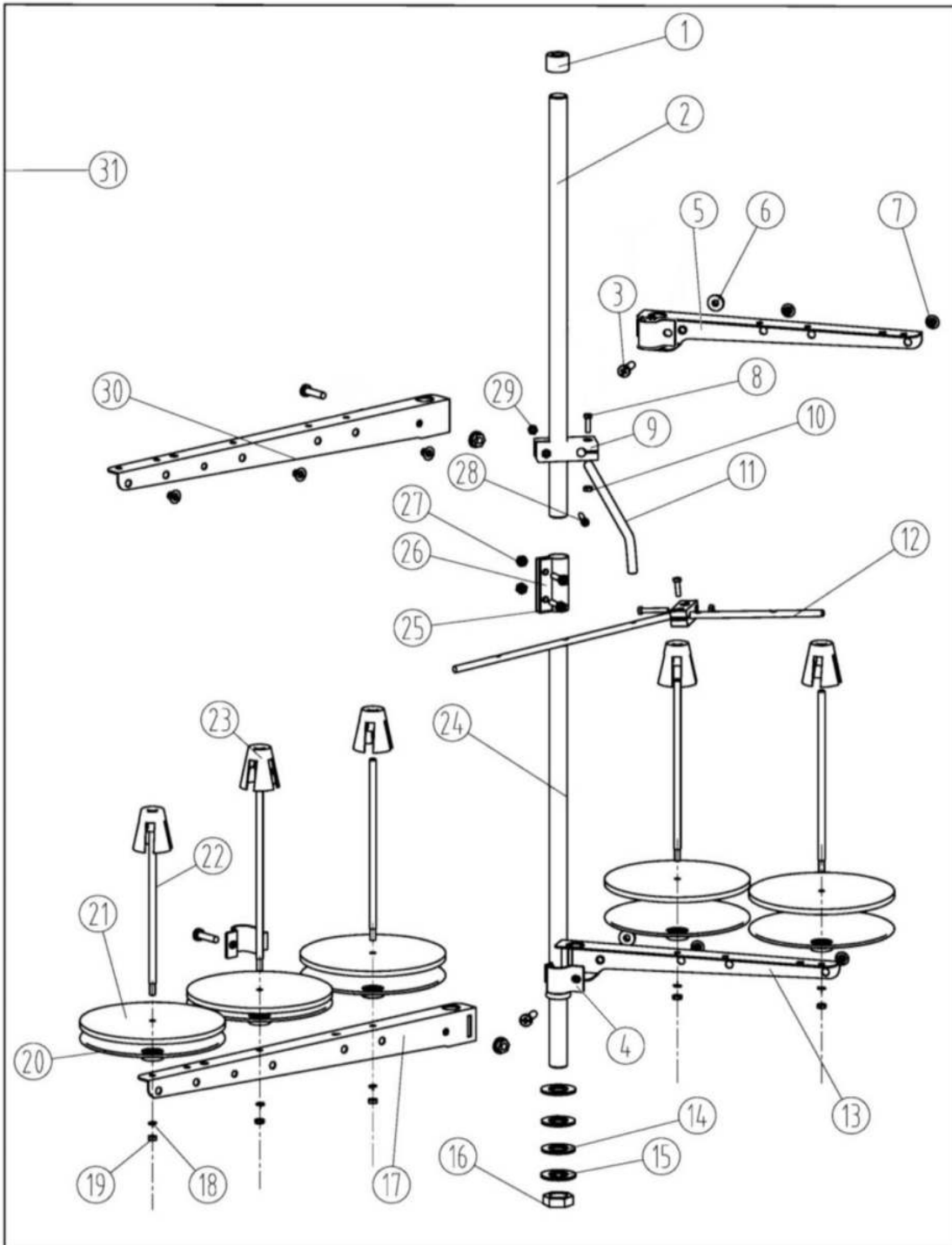

## 二十、 线架部件(Thread apool assemblies)

序号 Ref. No	公司件号 No	Part	参考件号 Ref. Part.	名称	Description	数量 Number
1	20131019			棒帽	Rod Cap	1
2	30131023			上管	Upper thread column	1
3	20131020			导线环螺钉	Screw	4
4	20131011			导线环	Thread spool tray bracket	2
5	21131026			导线架	Thread spool tray bracket	1
6	201S16006			导线环螺母	Thread guide hook nut	4
7	20131018			过线环	Thread guide hook	5
8	20131021			棒架螺钉	Screw	2
9	21131010			棒架	Clamp plate	1
10	201S16004			螺母	Nut	4
11	20131011			导线棒	Thread guide bar	1
12	30113019			过线棒	Thread guide	4
13	21131029			托线架	Thread spool tray bracket	1
14	20122049			防震垫	Plate dog link washer	2
15	20128025			下管垫圈	Lower washer	2
16	201S16005			螺母	Nut	1
17	21131028			托线架	Thread spool tray bracket	1
18	20128018			垫圈	Washer	5
19	201S16004			螺母	Nut	4
20	21131016			线盘	Spool tray	5
21	20131010			线盘垫	Spool tray cushioning	5
22	20131006			线托棒	Spool pin	5
23	21131015			线圈定位套	Spool Cushion	5
24	21131025			下管	Lower thread column	1
25	S04050			螺钉 M5×15	Screw	2
26	21131024			套	Bushing	1
27	N01030			套螺母	Nut	2
28	20131022			棒架螺钉	Screw	2
29	201S16004			螺母	Nut	4
30	21131027			导线架	Threadspooltray bracket	1
31	2113102500			线架组件	Thread stand component	1

台板部件（放在附件内）  
machine table mechanism (put in accessory)

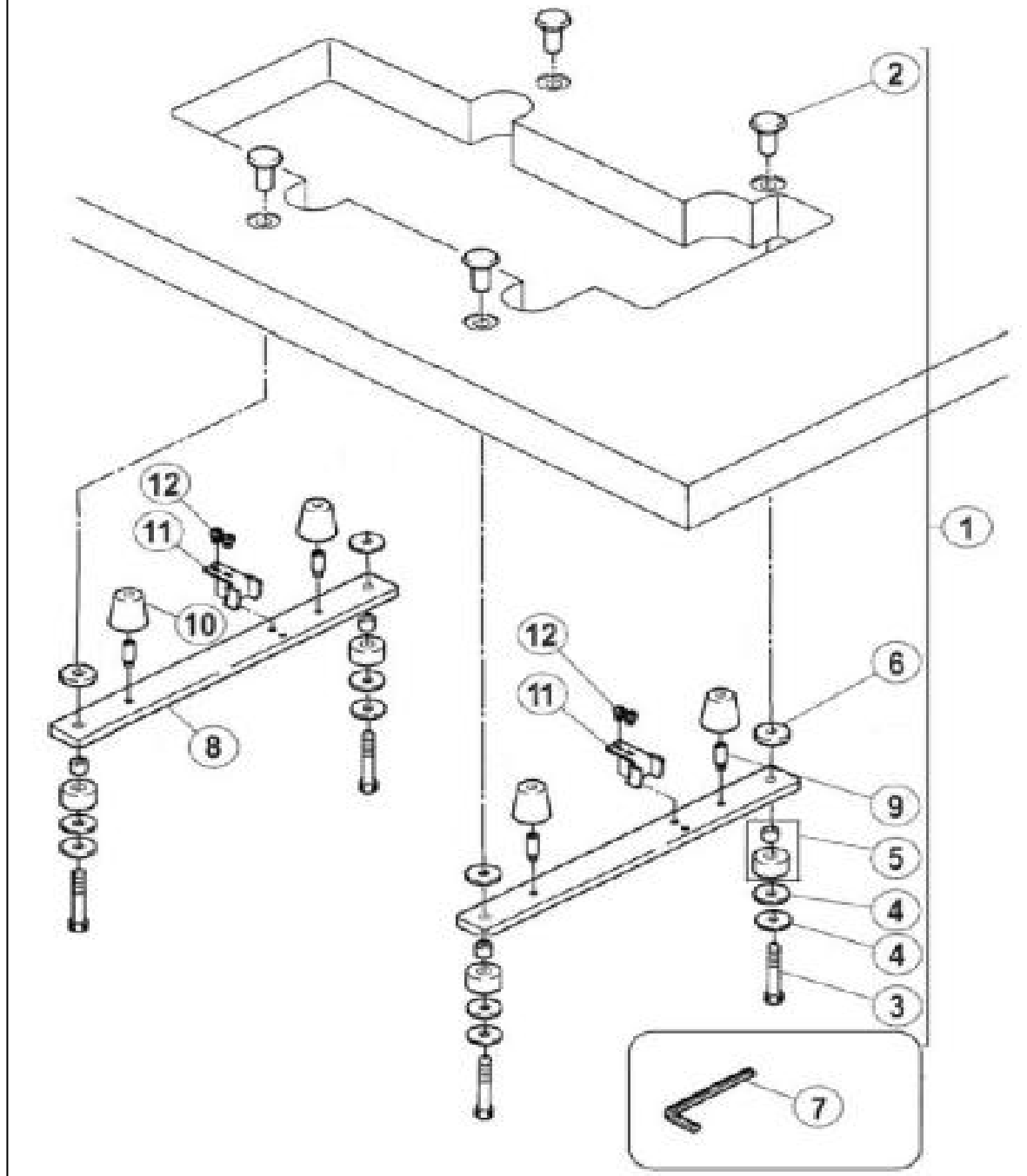

二十一、油盘托板部件(Oil plate assemblies)

序号 Ref.No	公司件号 Part No	参考件号 Ref. Part.	名称	Description	数量 Number
1	3010103200	9048	安装螺钉 (一套)	screw(set)	1
2	20131028	206336	托盘固定螺母	nut	4
3	20131027	4512	托板内六角螺钉	bolt	4
4	20131029	206337	大垫圈	washer	8
5	20131030	205764	防振套	rubber cushion	4
6	30122031	205467	减震垫圈	spacer	4
7	20131056	272	内六角扳手 (5mm)	allen key driver/5mm	1
8	30112198	259000	油盘托板	rest board	2
9	301S30018	7093	螺钉	screw	4
10	30122029	206338	油盘减振垫	rubber cushion	4
11	30112041	206329	链条挡板	treadle chain guide	2
12	S01011	7027	螺钉 M5×10	screw	4

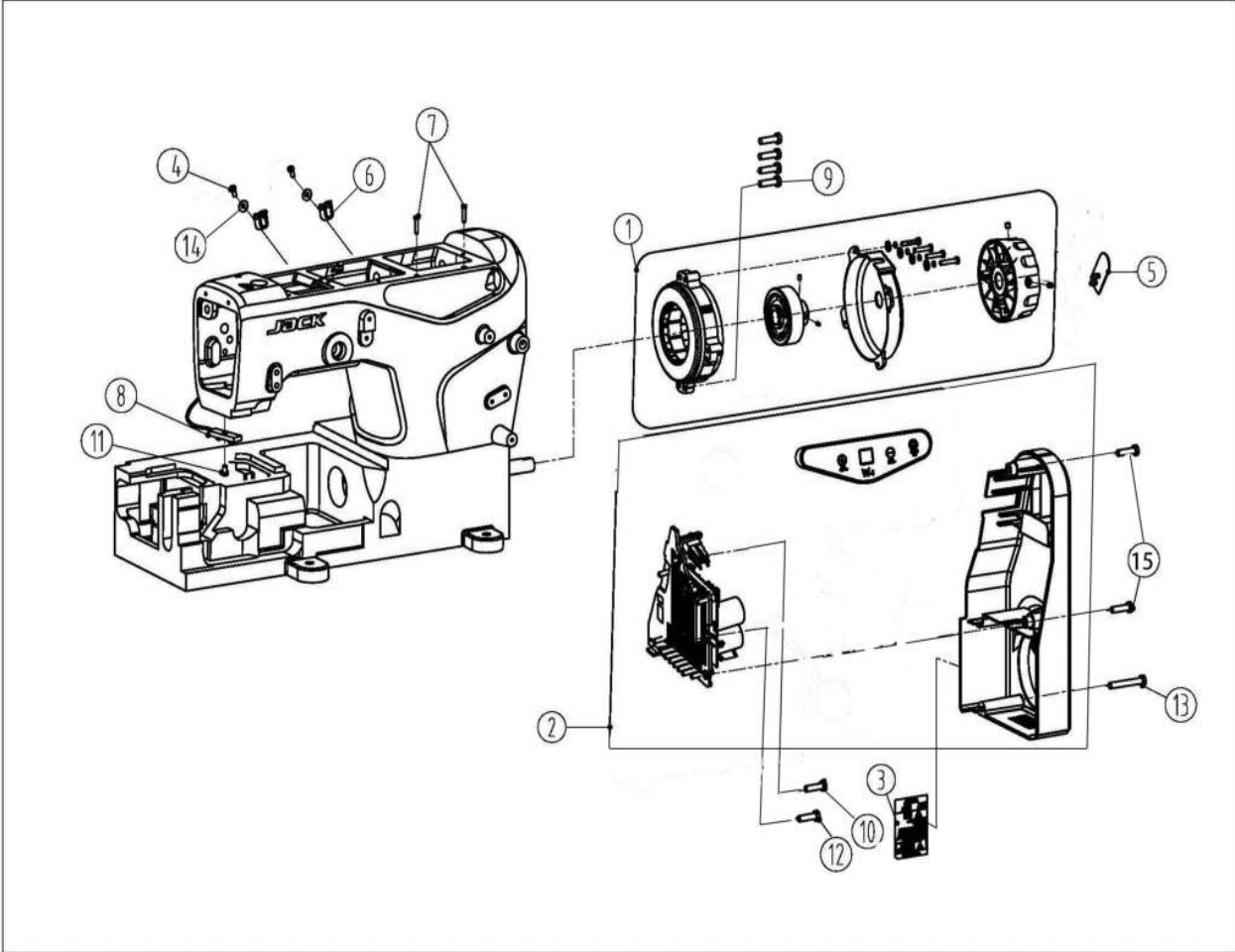

## 二十二、电控专用件(specific parts)

序号 Ref.No	公司件号 Part No	参考件号 Ref. Part.	名称	Description	数量 Number
1	3113300200		霍尔伺服电机	electrical machine	1
2	3113000400		电控组件	electrically controlled	1
3	20131063		警示牌	washer	1
4	207S11007		螺钉M5×5.5	screw	2
5	21111018		塑料logo	logo	1
6	20711210		线夹	clip	2
7	310s17001		螺钉	screw	2
8	3103000300		LED灯	LED light	1
9	S05004		螺钉M5×10	screw	4
10	S05003		螺钉M5×10	screw	1
11	s05190		螺钉M3x6	screw	1
12	S05003		螺钉M5×35	screw	1
13	S05003		螺钉M5×35	screw	1
14	W01001		垫片	washer	2
15	s05068		螺钉 M5×20		2

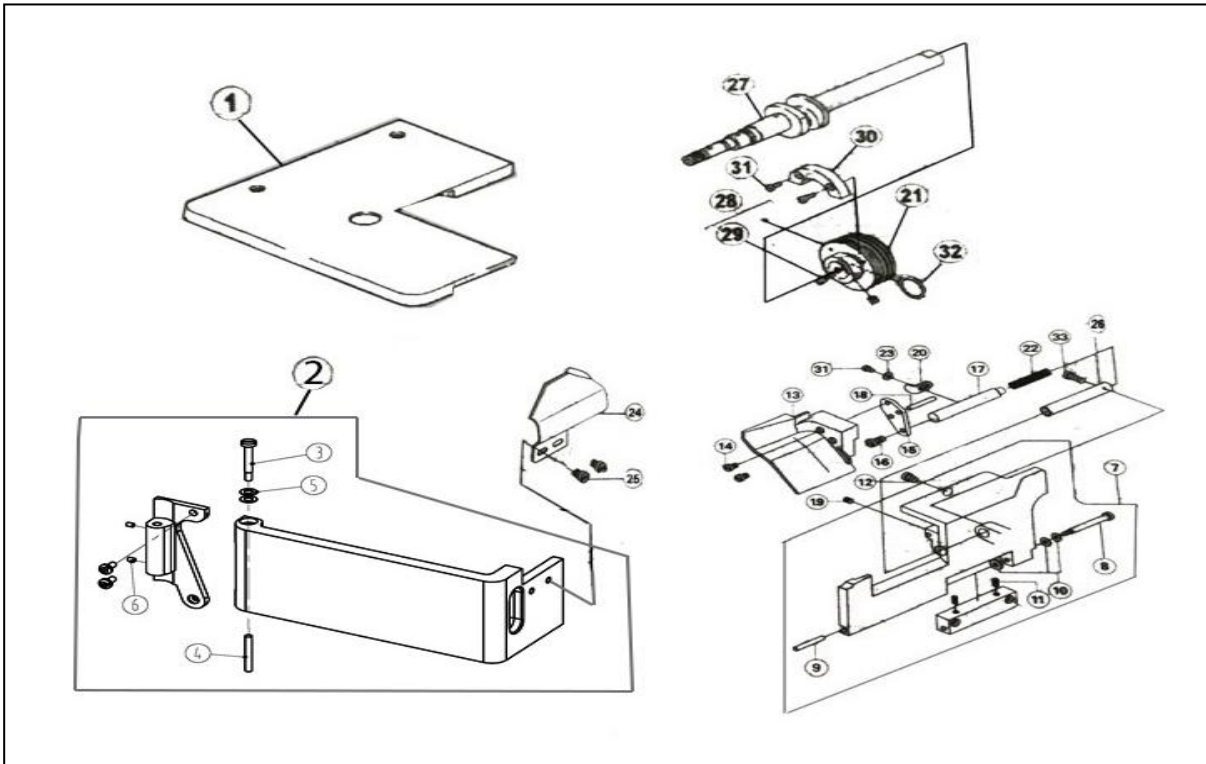

### 二十三、 05专用部件(05 specific parts)

序号Ref. No	公司件号 Part No	参考件号 Ref. Part.	名称	Description	数量 Number
1	300471		JK-8568-W05-25-1 左缝台盖(喷漆)		1
2	304425		W4-0309侧缝台组 件05(喷漆)		1
3	301S20004		侧盖合扇销钉		1
4	301S20005		销螺钉		1
5	30128002				2
6	S10001		螺钉 M3×4(进口)		2
7	302518		前罩缝台(喷漆)		1
8	301S20002				1
9	301S20003				1
10	30128002				3
11	S10006		螺钉 M5×6		2
12	30122015		前罩防振垫		1
13	30112045		前挡板		1
14	S01001		螺钉 M4×7		4
15	30112046		定位板		1
16	S01011		螺钉 M5×10		1
17	30102110		前挡板轴		1
18	30126010		平行销		1
19	S10002		螺钉 M5×5		1
20	30112160		挡板		1
21	3012400300		油封轴承		1
22	30127050		弹簧(删除)		1
23	W01002		M3垫片(普通)		1
24	30112044		左挡板		1
25	301S11020		压带轴螺钉		2
26	30103160		套筒		1
27	400068		主轴		1
28	30103003		前轴套		1
29	S10006		螺钉 M5×6		2
30	30109002		下轴平衡块		1
31	S01009		螺钉 M3×7.5		3
32	001001		O型圈 15×2.65		1
33	301S20026		十字槽盘头螺钉 M3×12(删除)		1

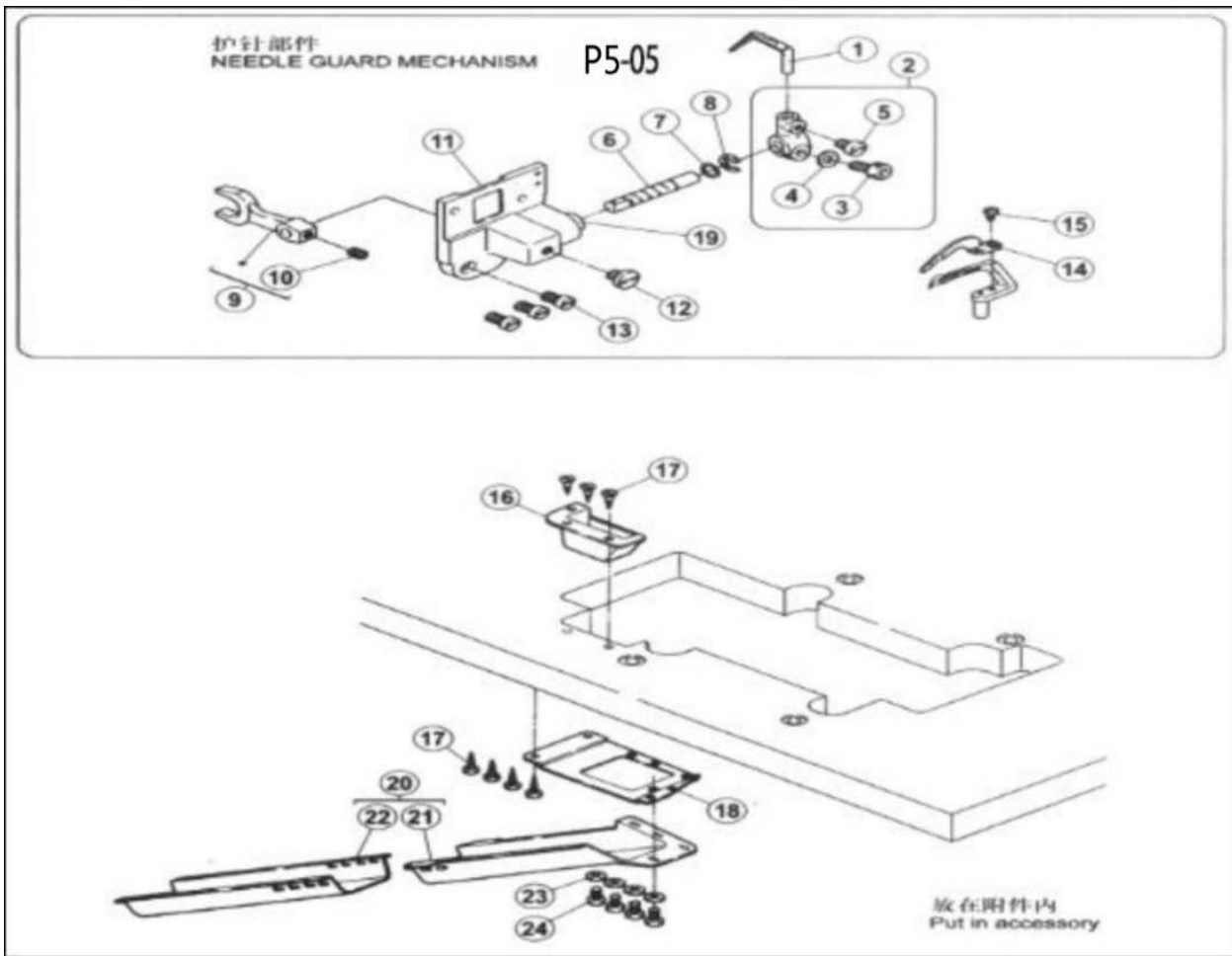

二十四、 05专用部件(05 specific parts)

序号Ref. No	公司件号 Part No	参考件号 Ref. Part.	名称	Description	数量 Number
1	30117002	357551B	后护针挡	needle guard(rear)	1
2	30117007	251505-92	护针挡架组件	lever assy	1
3	S05003	4500	螺钉 M5×10	bolt	1
4	W02001	303067	垫圈5	washer	1
5	S01002	7017	螺钉 M4×6.5	screw	1
6	30102037	251503	护针轴	shaft	1
7	W01021		垫片	washer	1
8	H05013	202522	挡圈6	ring	1
9	400064	251504	叉架	lever	1
10	S10002	4514	螺钉 M5×5	screw	1
11	30101036	251500-91	护针轴座	bracket	1
12	301S11016	7081	螺钉	screw	1
13	S01004	7019	螺钉 M4×7.8	screw	3
14	30117003		前护针挡	needle guard(front)	1
15	S01012		螺钉 M2.5×4	screw	1
16	30111013	306473-UA	挡料斗	waste chute top(C)	1
17	301S30019	4905	木螺钉	screw	7
18	30112048	306474A	托板	bracket	1
19	30103046		套筒	bushing	1
20	3011101400		排料筒座组件	waste chute	1
21	30111014	205468-UA	排料筒座	waste chute top(A)	1
22	30111015	205469-UA	排料筒	waste chute top(B)	1
23	30128036		垫片	washer	1
24	S01005	7020	螺钉 M4×10	screw	4

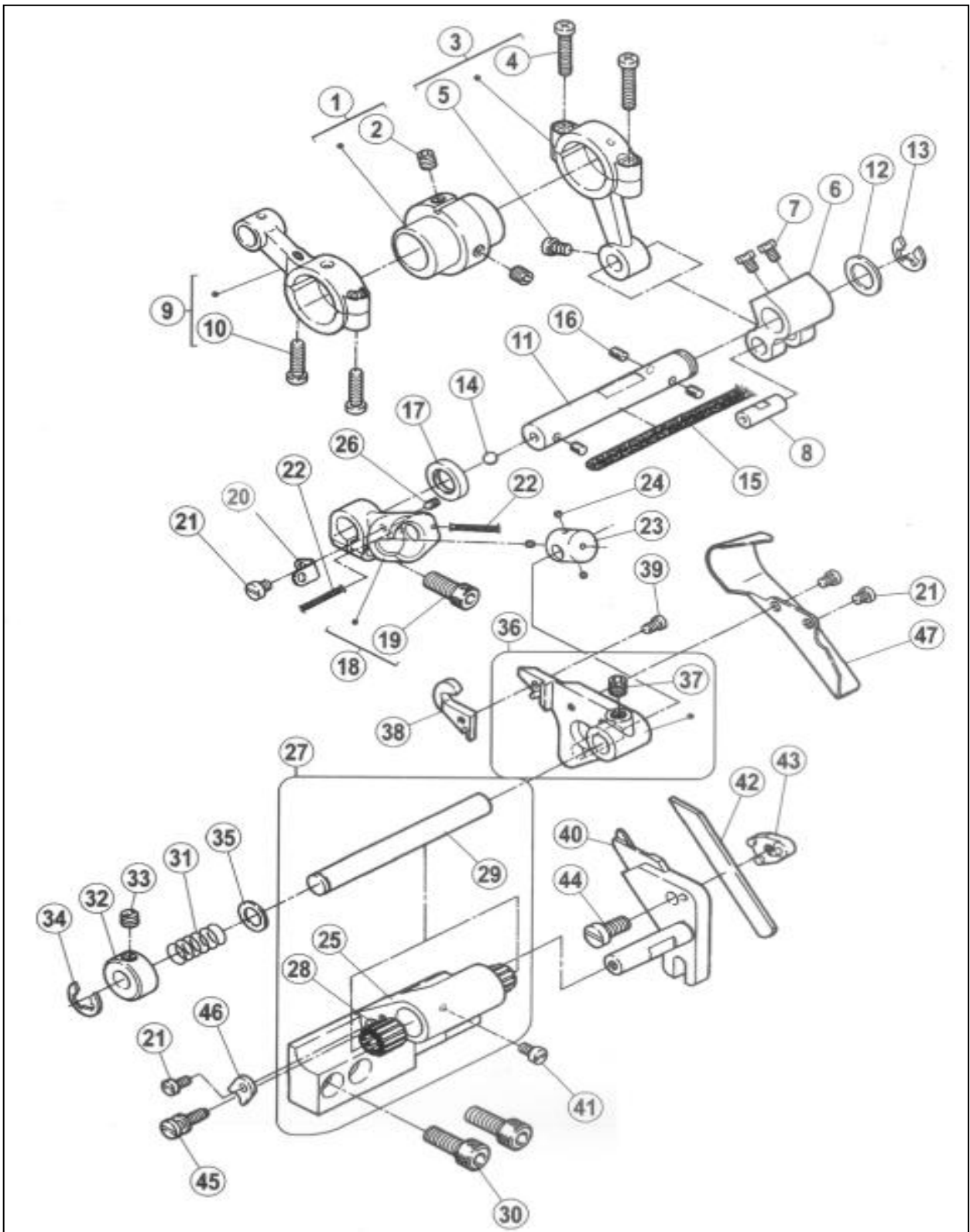

## 二十五、05专用部件 (05 specific parts)

序号Ref. No	公司件号 Part No	参考件号 Ref. Part.	名称	Description	数量 Number
1	30110009	255500	凸轮	eccentric assy	1
2	S10006	4539	螺钉 M5×6	screw	2
3	400062		连杆组件	eccentric assy	1
4	S01008		螺钉 M3.5×13	screw	4
5	S01010		螺钉 M4×8	screw	1
6	30104007		弯针曲柄	crank	1
7	301S12001		螺钉	screw	2
8	30126003		曲柄销	pin	1
9	400063		弯针摆动连杆	connection assy	1
10	S01008		螺钉 M3.5×13	screw	2
11	30102038	255502	曲柄轴	shaft	1
12	30128008	240102	护针轴垫圈	washer	1
13	H05001		垫圈10	ring	1
14	30209009		差动轴滚珠	ball	1
15	30123014		油线	oil wick	1
16	30123001		毛毡	felt	3
17	30122019		油封	oil seal	1
18	30104028	255503	摆轴曲柄	lever assy	1
19	S05004		螺钉 M5×14	screw	1
20	30112049	255504	挡板	latch	1
21	S01006	7009	螺钉 M3×4.5	screw	4
22	30123015		油线	oil wick	2
23	30102039	255505	摆轴	shaft	1
24	30123008		毛毡	felt	3
25	30101040		刀座	bracket assy	1
26	S12002		螺钉 M3×4	screw	1
27	3010104000		刀座组件	bracket assy	1
28	30103085		刀座套筒	needle bearing	2
29	30102040	255508-2	下刀座轴	shaft	1
30	S05019		螺钉 M6×16.3	screw	2
31	30127022	306105	弹簧	spring	1
32	30108006	192024	挡圈	ring	1
33	209S14008	W00024-1	螺钉	screw	1
34	H05013	202522	挡圈	ring	1
35	30128026	207045	垫片	washer	1
36	30101037	255507-91	上刀架	upper knife holder	1
37	S12003	4547	螺钉 M6×0.75×5	screw	1
38	30119001	306394	上刀	upper knife	1
39	301S11017	5109	上刀固定螺钉	screw	1
40	30101039	255509	下刀架	lower knife holder	1
41	301S11025	7036	护针曲柄螺钉	screw	1
42	20619004	204161	下刀	lower knife	1
43	30101038	255510	下刀挡板	lower knife clamp	1
44	S01011	7028	螺钉 M5×10	screw	1
45	301S30021	255513	调节螺钉	screw	1
46	30112051	255511	挡片	guide	1
47	30112050	255515	除削板	chip guard	1

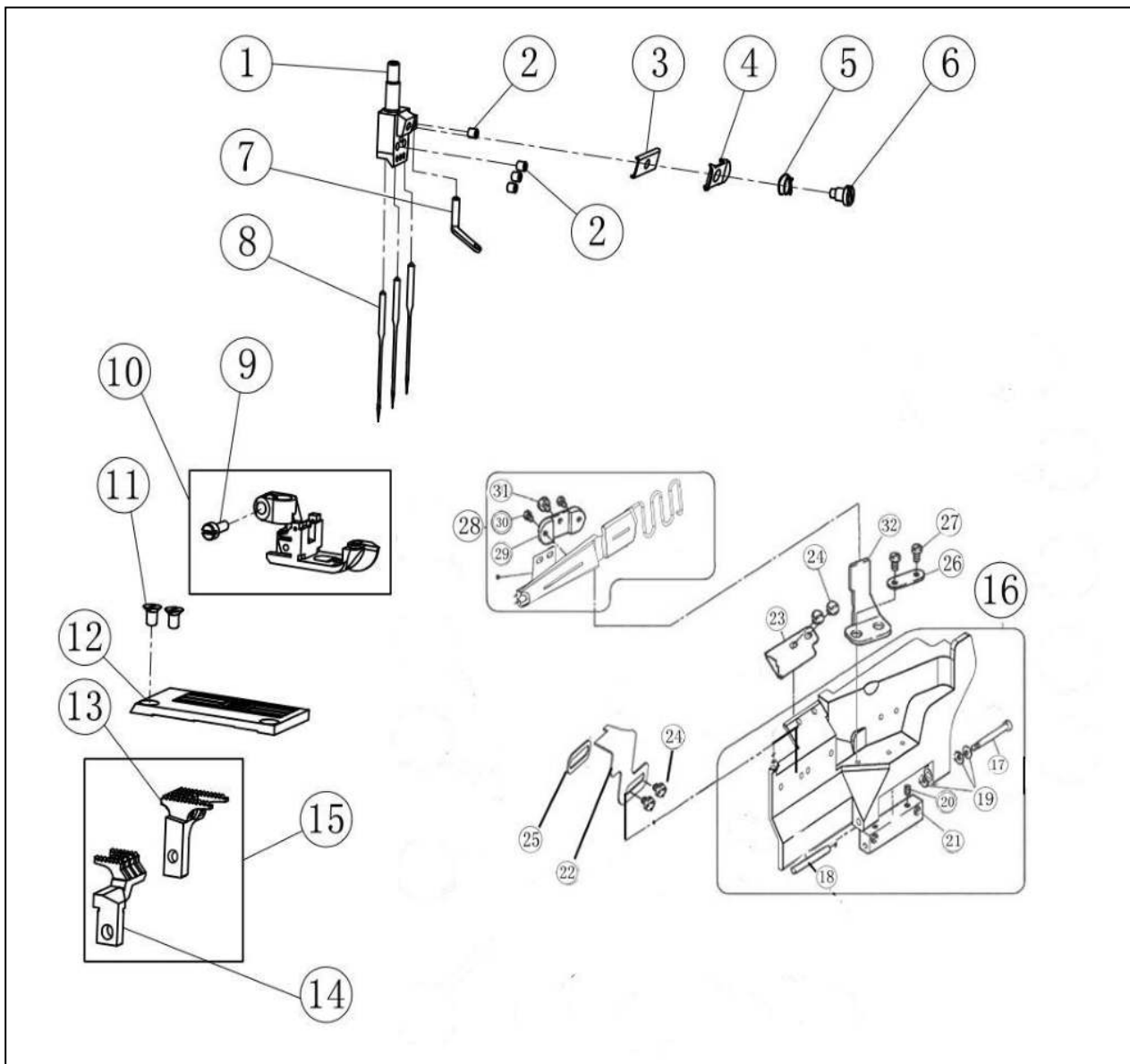

## 二十六、 针位组部件( specific parts)

序号Ref. No	公司件号 Part No	参考件号 Ref. Part.	名称	Description	数量Number
1	30134001		356针古	needle holder	1
	30134002		364针古	needle holder	1
2	S10026	4554	螺钉M3X3	screw	4
3	30112025	234561	夹线板	thread guide	1
4	30112026	253593	压线板	tension disc	1
5	30127014	253517	调压簧	spring	1
6	301S20009	0W09070-2	调线螺钉	screw	1
7	30112033	253511	喂针小过线	thread guide	1
8	30117001		机针	sponge	3
9	301S11010	1170-3	压脚固定螺钉	screw	1
10	3021601000		压脚(01GB)	presser foot assv(01GB)	1
	30116005		压脚(02BB*356)	presser foot assv(02BB*356)	1
	30116006		压脚(02BB*364)	presser foot assv(02BB*364)	1
11	302S17001		螺钉(进口)	screw	2
12	30115067		356针板(01GB)	needle plate(01GB*356)	1
	30115068		364针板(01GB)	needle plate(01GB*364)	1
	30115006		356针板(02BB)	needle plate(02BB*356)	1
	30115007		364针板(02BB)	needle plate(02BB*364)	1
13	30214001		送布牙(01GB)	main feed dog(01GB)	1
14	30214002		差动牙(01GB)	diff feed dog(01GB)	1
15	3021400100		送布差动牙组件 (01GB)	main feed dog and diff feed	1
	30214008		送布牙(02BB)	main feed dog(02BB)	1
	30214009		差动牙(02BB)	diff feed dog(02BB)	1
16	303796	250033-SD	前罩缝台组件	front cover	1
17	301S20002	250013	前罩缝台座螺钉	screw	1
18	301S20003	250014	前罩缝台座螺钉	screw	1
19	30128002	201191	弹簧垫圈	spring	3
20	S10002		螺钉 M5×5	screw	2
21	30101063	250012	前罩缝台座	bracket	1
22	31112012		前缝台挡板	screw	1
23	30112061	206601A	缝料挡板	fabric guard	1
24	S01065	7079	螺钉 M5×6	screw	4
25	31112011		挡板垫片	auxiliary plate/front cover	1
26	30112063	206460	龙头架垫	washer	1
27	S01011	7028	螺钉 M5×10	screw	2
28	3011206800		龙头组件	bracket assy	1
29	30109019	201913	龙头固定板	bracket	1
30	301S30051	5113	螺钉	screw	2
31	L02009		螺栓 M6×10	bolt	1
32	30112062	201914	龙头架	bracket	1

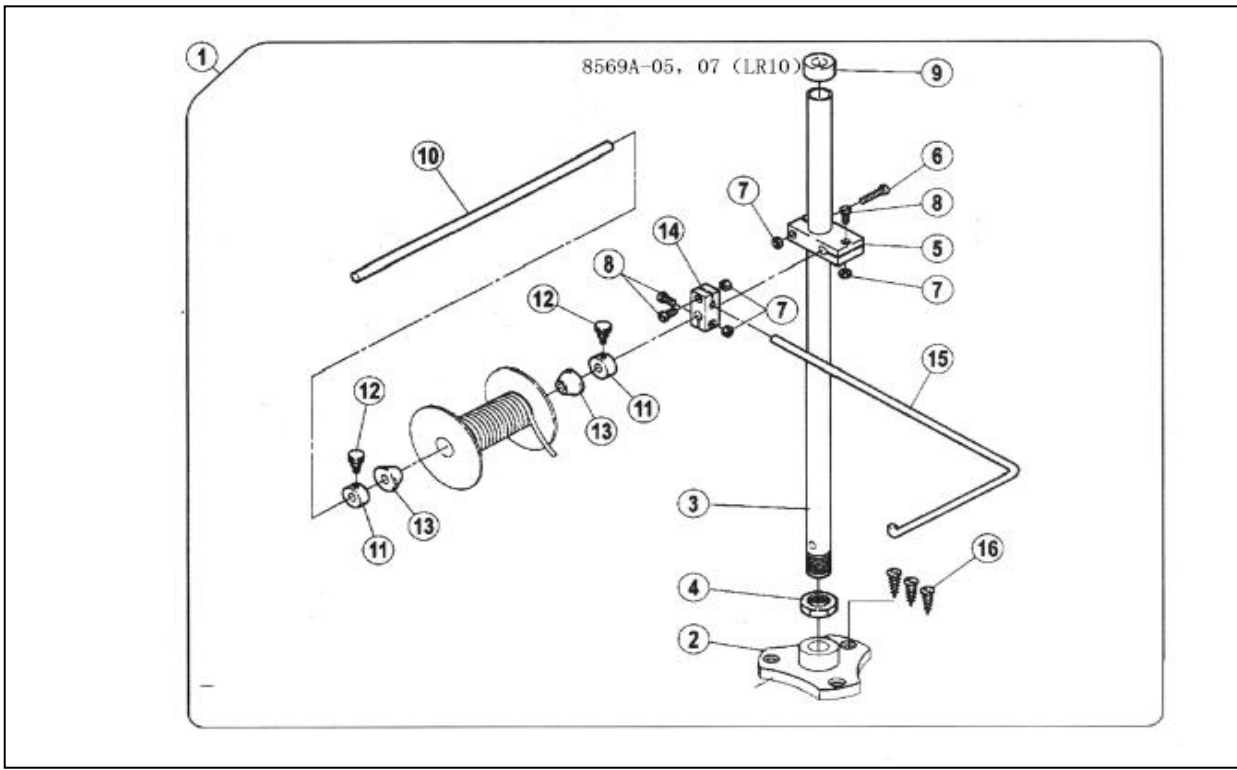

二十七、05、07专用部件 (05、07 specific parts)

序号Ref. No	公司件号 Part No	参考件号 Ref. Part.	名称	Description	数量 Number
1	3010204100	306469A9S	带子组件	reel stand	1
2	30103047	306468-SA	支柱盘	bracket	1
3	30102042	306466-SA	支柱	rod	1
4	N02001		螺母SM3/4×16	nut	1
5	30111008	383-SA	棒架	bracket	1
6	S04003		螺钉 M4×25	screw	1
7	N01005		螺母 M4	nut	4
8	S04004		螺钉 M4×15	screw	3
9	30122027	386	棒帽	rod cap	1
10	30102043	306464	带架直棒	shaft	1
11	30103048	306463	轴古	collar	2
12	S01068		螺钉 M4×8	screw	2
13	30103064	306462	轴锥架	reel guide	2
14	30111009	233-SA	固定器	bracket	1
15	30113020	306467	带架棒	rod	1
16	301S30022	4913	木螺钉	screw	3

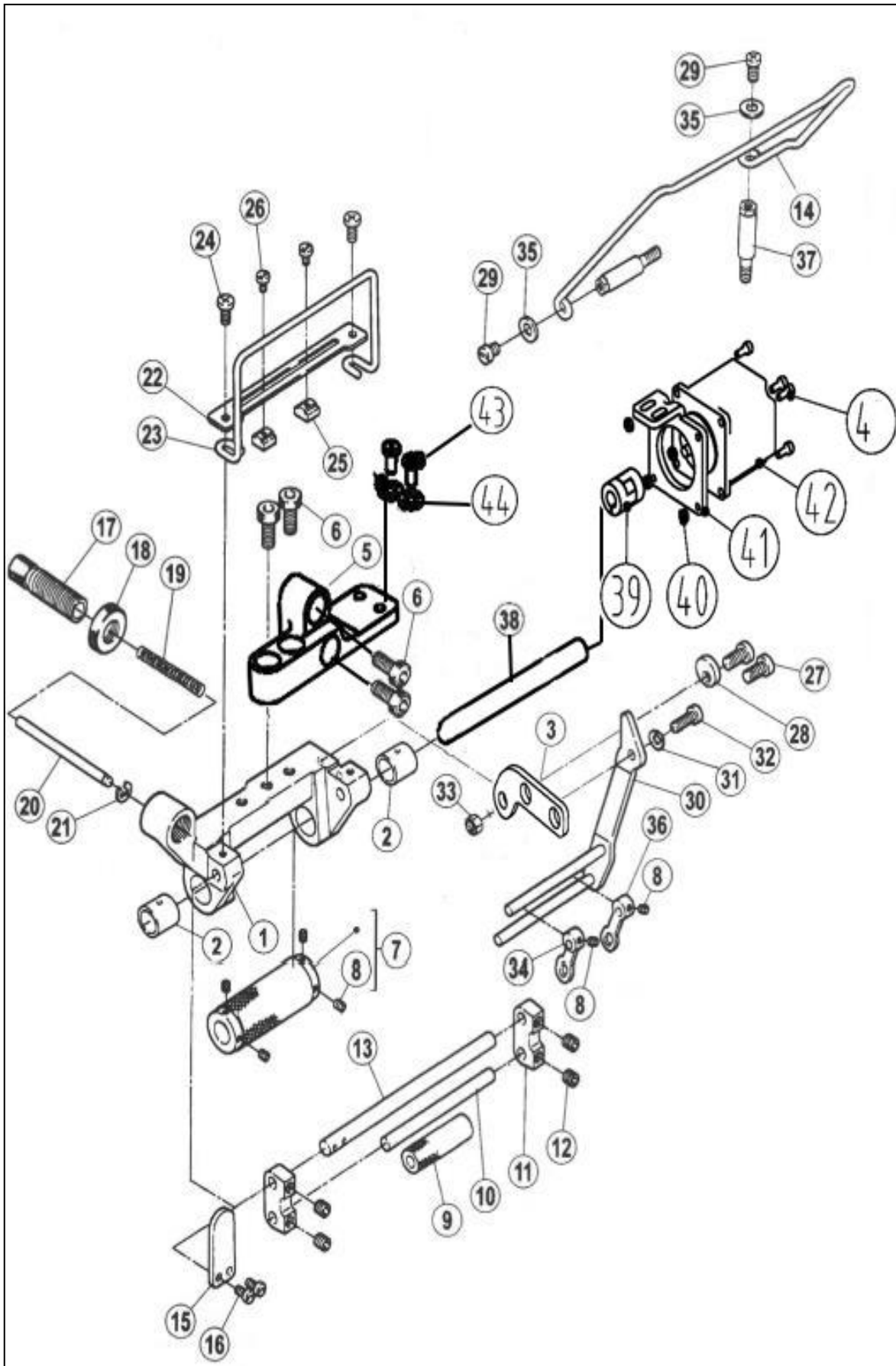

二十八、05、07专用部件 (05、07 specific parts)

序号Ref. No	公司件号 Part No	参考件号 Ref. Part.	名称	Description	数量Number
1	300144		压带架座	bracket assy	1
2	30103055		套筒	bushing	2
3	31112017		W4-3004夹带连接板	bracket	1
4	S01005		螺钉M4X10		4
5	304427		压带架支座(喷漆)	bracket	1
6	S05019		螺钉 M6×16.3	screw	4
7	3010305700		压带轮组件	roller assy	1
8	S10005		螺钉 M3×3	screw	6
9	30103059		压带轮 II	rooler	1
10	30102045		夹带短轴	shaft	1
11	30109018	255502	夹带轴架	bracket	2
12	S10002	240102	螺钉 M5×5	screw	4
13	30102046		夹带长轴	shaft	1
14	30113021		带子架	lace guide	1
15	30112059		手柄	lever	1
16	S01027		螺钉 M3×5	screw	2
17	301S30027		调节螺钉	screw	1
18	301S16011	255503	调节螺母	nut	1
19	30127024		弹簧	spring	1
20	30126013	255504	销轴	shaft	1
21	H05002	7009	挡圈5	ring	1
22	30112055		压带板	guide	1
23	30113022	255505	压带架	lace guide	1
24	S01002		螺钉 M4×6.5	screw	2
25	301S16010		位置挡块	guide	2
26	301S11018		螺钉	screw	2
27	S01004		螺钉 M4×7.8	screw	2
28	30128028		偏心垫	stopper	1
29	S01004	255508-2	螺钉 M4×7.8	screw	2
30	3011205600		夹带架组件	bracket assy	1
31	30128020	306105	垫片	spring	1
32	S05048	192024	螺钉 M4×10	screw	1
33	N01001	W00024-1	螺母 M4	nut	1
34	30105017	202522	夹带连杆 I	lace guide	1
35	W01004	207045	垫圈5	washer	2
36	30105018	255507-91	夹带连杆 II	lace guide	1
37	301S30025	4547	台螺钉	screw	2
38	31102003		W4-3001滚轮轴		1
39	31103002		W4-3010弹性联轴		1
40	N01001		螺母 M4		4
41	31112016		W4-3003电机安装座		1
42	3113300300		W4-3012绷缝步进电机		1
43	S01011		GB/T65-1985螺钉 M5×10		2
44	W01009		GB/T97.1-1985垫 圈5		2

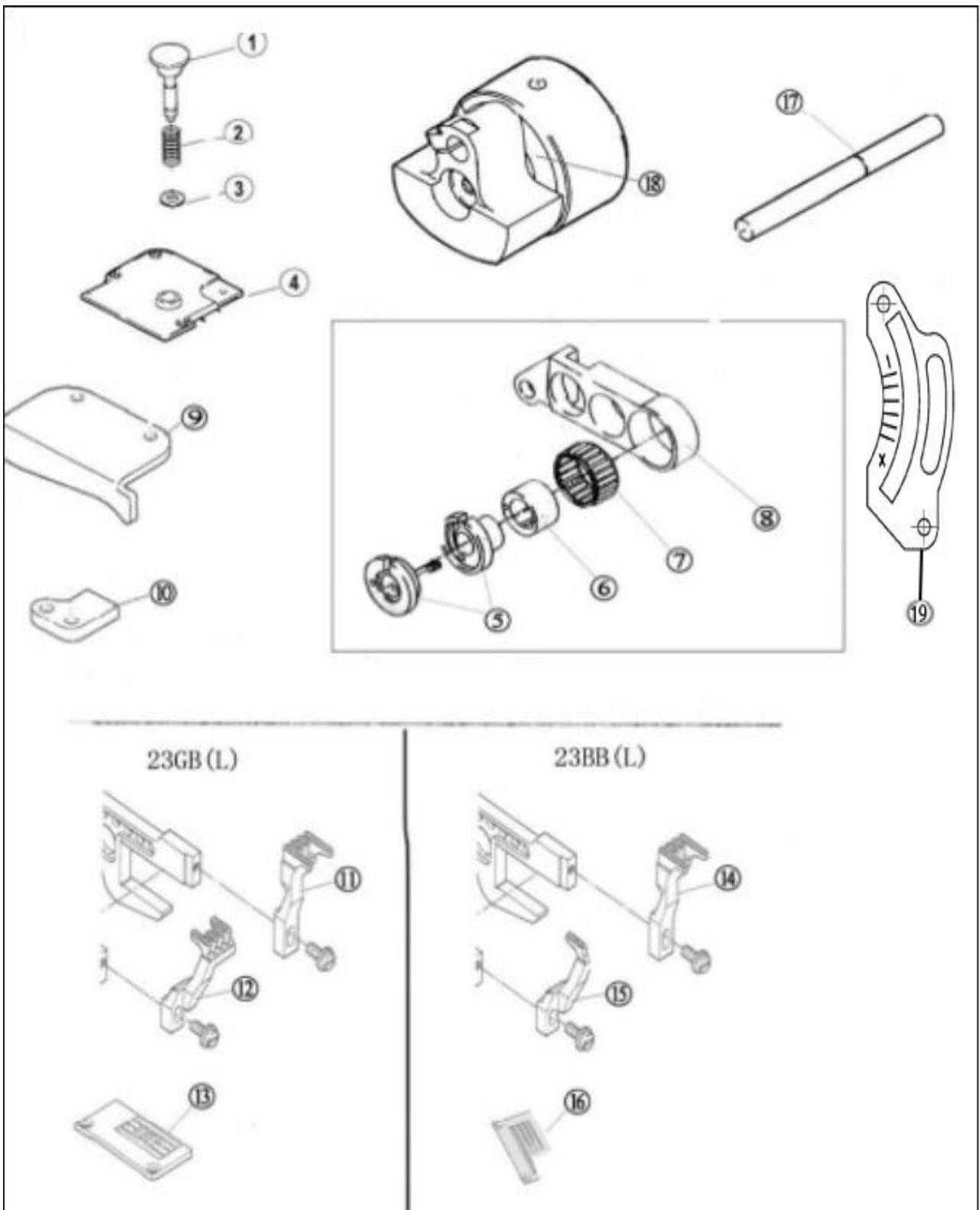

## 二十九、23专用部件(23 specific parts)

序号 Ref. No	公司件号 No	Part	参考件号 Ref. Part.	名称	Description	数量 Number
1	30126016			针距调节按钮	pin	1
2	30127026			针距调节簧	spring	1
3	12928008			平垫圈	washer	1
4	30101162			下节左盖	cover	1
5	3010308900			调节器套组(大针距)	eccentric retainer	1
	30103150			送布调节器	regulator	1
6	30103100			偏心轴承套(大针距)	eccentric	1
7	B07043			轴承19×23×10	needle bearing	1
8	30104060			差动送布架(大针距)	Link/main feed	1
9	30109025			左挡板	guide (left)	1
10	30109026			挡板	guide (lower)	1
11	30114028			送布牙	main feed dog	1
12	30114029			差动牙 (356/364)	differntial feed dog	1
13	30115041			23GB针板(356)	needle plate	1
	30115042			23GB针板(364)	needle plate	1
14	30114030			送布牙	main feed dog	1
15	30114031			差动牙 (356/364)	differntial feed dog	1
16	30115045			2302BB针板	needle plate	1
	30115046			2302BB针板	needle plate	1
17	30102051			摆轴	shaft	1
18	31104002			针杆曲柄	motion assy	1
19	30112220			调节板		1

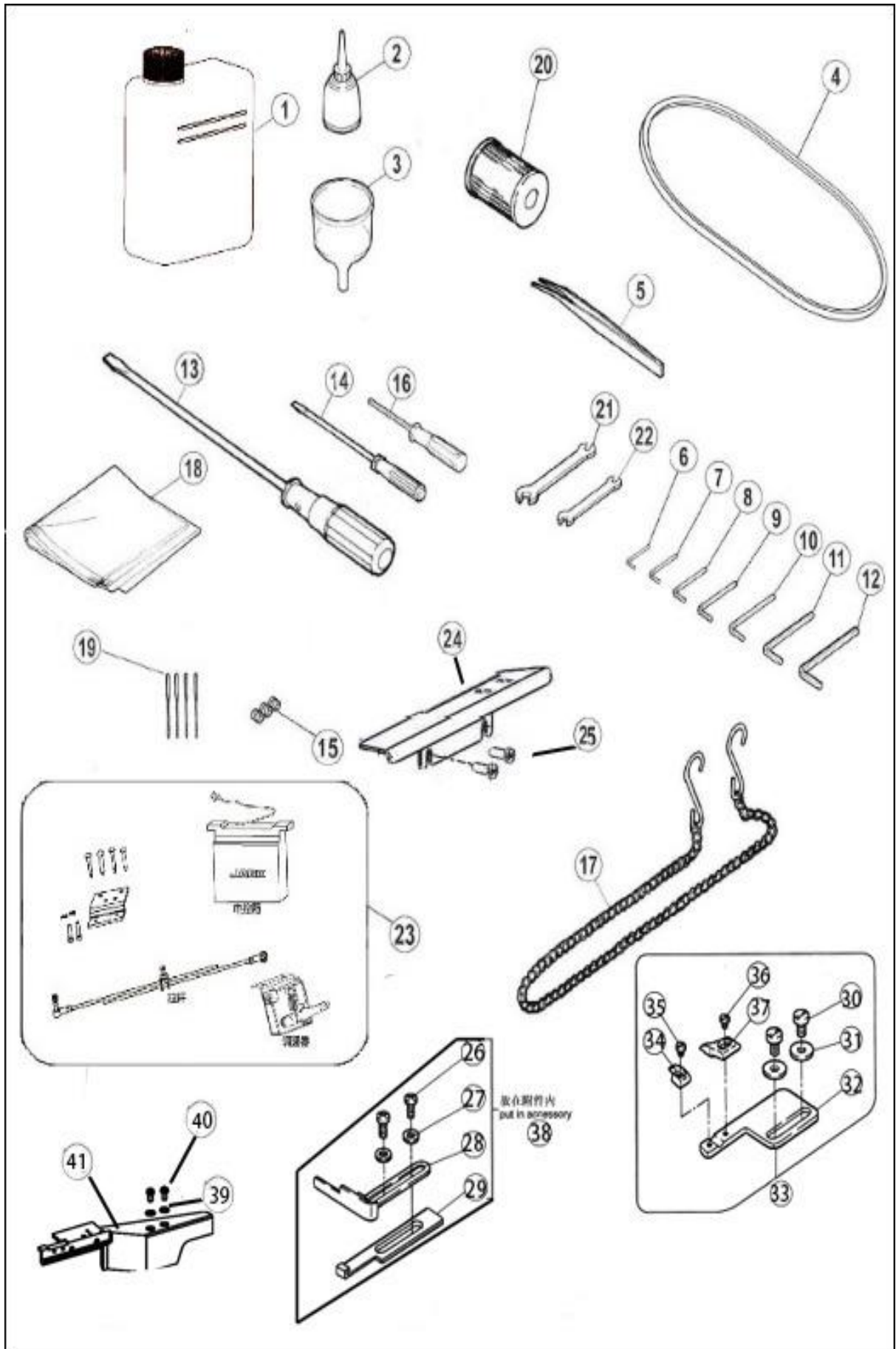

### 三十、附件部件 (Accessories assemblies)

序号Ref. No	公司件号 No	Part	参考件号 Ref. Part.	名称	Description	数量Number
1	20131037			油壶 (大)	oil container	1
2	20131038			小油壶 (尖嘴)	oiler	1
3	20131039			漏斗	oil funnel	1
4	30135004			皮带 (非直驱专用)	leather belt	1
5	20131051			镊子	tweezers	1
6	30131007			内六角扳手 (1.5mm)	allen key driver/1.5mm	1
7	20131046			内六角扳手 (2mm)	allen key driver/2mm	1
8	30131010			内六角扳手 (2.5mm)	allen key driver/2.5mm	1
9	30131012			内六角扳手 (3mm)	allen key driver/3mm	1
10	20131047			内六角扳手 (4mm)	allen key driver/4mm	1
11	20131056			内六角扳手 (5mm)	allen key driver/5mm	1
12	30131026			内六角扳手 (6mm)	allen key driver/6mm	1
13	20731047			螺丝刀 (大)	screwdriver (large)	1
14	10131004			螺丝刀 (小)	screwdriver (small)	1
15	S10005			螺钉 M3×3	screw	3
16	20131044			内六角扳手 (1.5mm直柄)	allen key driver/1.5mm	1
17	30131018			链条 (非直驱、DI专用)	chain	1
18	10131005			机头罩	dust cover	1
19	30117001			机针	needle	4
20	20136001			滤油器	filter element	1
21	30131005			扳手 (7mm-9mm)	wrench/(7mm-9mm)	1
22	30131006			扳手 (8mm-10mm)	wrench/(8mm-10mm)	1
23	3013001100			直驱控制器 (直驱专用)	DI Special Part	1
24	304120			加宽前门板组件 (喷漆)		1
25	S01011			螺钉 M5×10		2
26	301S11024			滑块导座螺钉	screw	2
27	W01001			垫圈4	washer	2
28	30112065			缝料挡板1	fabric guide	1
29	30112066			缝料挡板2	fabric guide	1
30	S01011			螺钉 M5×10	screw	2
31	W01009			垫圈5	washer	2
32	30112064			盖缝附件2	bracket	1
33				03附件		1
34	30109020			盖缝附件1	fabric guide	1
35	S01036			螺钉 M3×3	screw	1
36	S01036			螺钉 M3×3	screw	1
37	30109021			盖缝附件3	fabric guide	1
38				08附件		1
39	W01009			垫圈5		2
40	S01011			螺钉 M5×10		2
41	304252			W4-0301前罩缝台盖		1

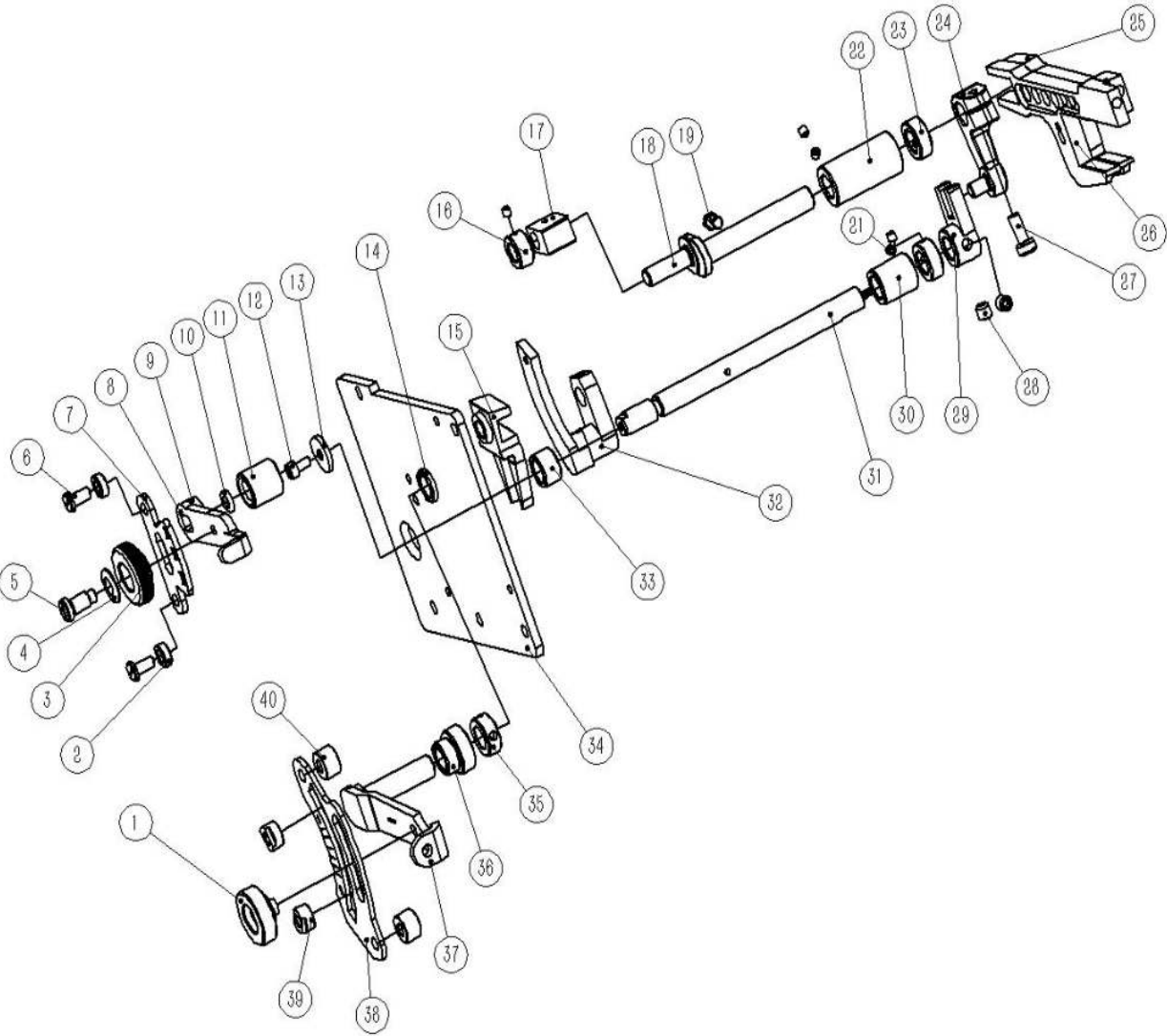

三十一、薄厚料方便调节部件(Thin and thick transform specific parts)

序号Ref. No	公司件号 Part No	参考件号 Ref. Part.	名称	Description	数量Number
1	301S16004		滚花螺母		1
2	13803012		A4-0709-02短套		2
3	301S16004		螺母		1
4	30128014		垫圈		1
5	301S30007		调节扳手螺钉		1
6	301S11024		滑块导座螺钉M4×8		2
7	131312007		W4S-3006刻度板		1
8	131312005		手		1
9	3052201500		骨架油封 φ19×φ 14×3		1
10	001009		O型圈 4.5×1.8		1
11	131303004		套		1
12	311S05001		针杆螺钉M3×6		1
13	20428010		垫片		1
14	30103089		差动调节扳手套		1
15	30109016		JK-8569-W10-2比叉		1
16	131308002		圈		1
17	131309002		块		1
18	131302002		W4S-3007偏心轴		1
19	301S12001		螺钉SM11/64×40		1
21	S10005		M3×3		5
22	131303005		筒		1
23	131308001		W4S-3005挡圈		2
24	131304002		柄		1
25	30106001		送布牙架		1
26	30106002		差动牙架		1
27	S05048		曲柄螺钉M4×10		1
28	S10002		紧定螺钉M5×5		2
29	131304001		柄		1
30	131303003		套		1
31	131302001		W4S-3001差动轴		1
32	30104016		JK-8569-W9-51差动 调整架		1
33	30103030		JK-8569-W9-57差动 轴前套筒		1
34	13131200400		左板组件		1
35	30108004		差动调节扳手轴挡		1
36	30103089		差动调节扳手套		1
37	3011201300		调节扳手组件		1
38	30112015		调节板		1
39	20109005		调节滑块		1
40	30203019		调节套		1