

杰克缝纫机
全球销量遥遥领先
Leading in global sales

400-8876-858
www.chinajack.com



JACK SEWING MACHINE CO.,LTD.

2017年6月份 Edition: June, 2017

杰克缝纫机股份有限公司

浙江省台州市椒江区机场南路15号
电话 :0086-576-88177788 88177789
传真 :0086-576-88177758
产品标准代号 : Q/TK 007-2017
资料如有更改, 恕不另行通知, 以实样为准

JACK SEWING MACHINE CO.,LTD.

No. 15 Airport South Road, Jiaojiang District, Taizhou, Zhejiang, PRC
TEL: 0086-576-88177782 88177767 E-mail: sales@chinajack.com
FAX: 0086-576-88177787 www.chinajack.com
Standard code of the products: Q/TK 007-2017
You will be not informed if the file has been revised. Please set sample as standard.



JK-T1790G
零件图册
Parts book

JACK 杰克

CONTENTS

目 录

1. FRAME & MISCELLANEOUS COVER COMPONENTS (1).....	1
头部·外装置部件 (1)	
2. FRAME & MISCELLANEOUS COVER COMPONENTS (2).....	3
头部·外装置部件 (2)	
3. MAIN SHAFT COMPONENTS.....	5
上轴部件	
4. HOOK DRIVING SHAFT COMPONENTS.....	7
下轴部件	
5. PRESSER & FEED COMPONETS.....	9
压脚·送料部件	
6. NEEDLE BAR ROCKING COMPONENTS.....	11
针杆摇动部件	
7. NEEDLE THREAD TRIMMER COMPONENTS.....	13
上剪线部件	
8. BOBBIN THREAD TRIMMER COMPONENTS.....	15
下剪线部件	
9. CLOTH CUTTING KNIFE COMPONENTS.....	17
切刀部件	
10. TABLE COMPONENTS.....	19
台板部件	
11. CONTROL BOX COMPONENTS.....	21
电控箱部件	
12. OPERATION BOX COMPONENTS.....	23
操作面板部件	
13. ACCESSORIE PART COMPONENTS.....	25
附件	
14. THREAD STAND COMPONENTS.....	27
线架装置部件	
15. SPECIAL SPECIFICATIONS COMPONENTS.....	28
特殊类型部件	
16. BOTTOM LINE DETECTION MECHANISM.....	30
底线检测装置 (选配)	

1. FRAME & MISCELLANEOUS COVER COMPONENTS (1)

头部·外装置部件(1)

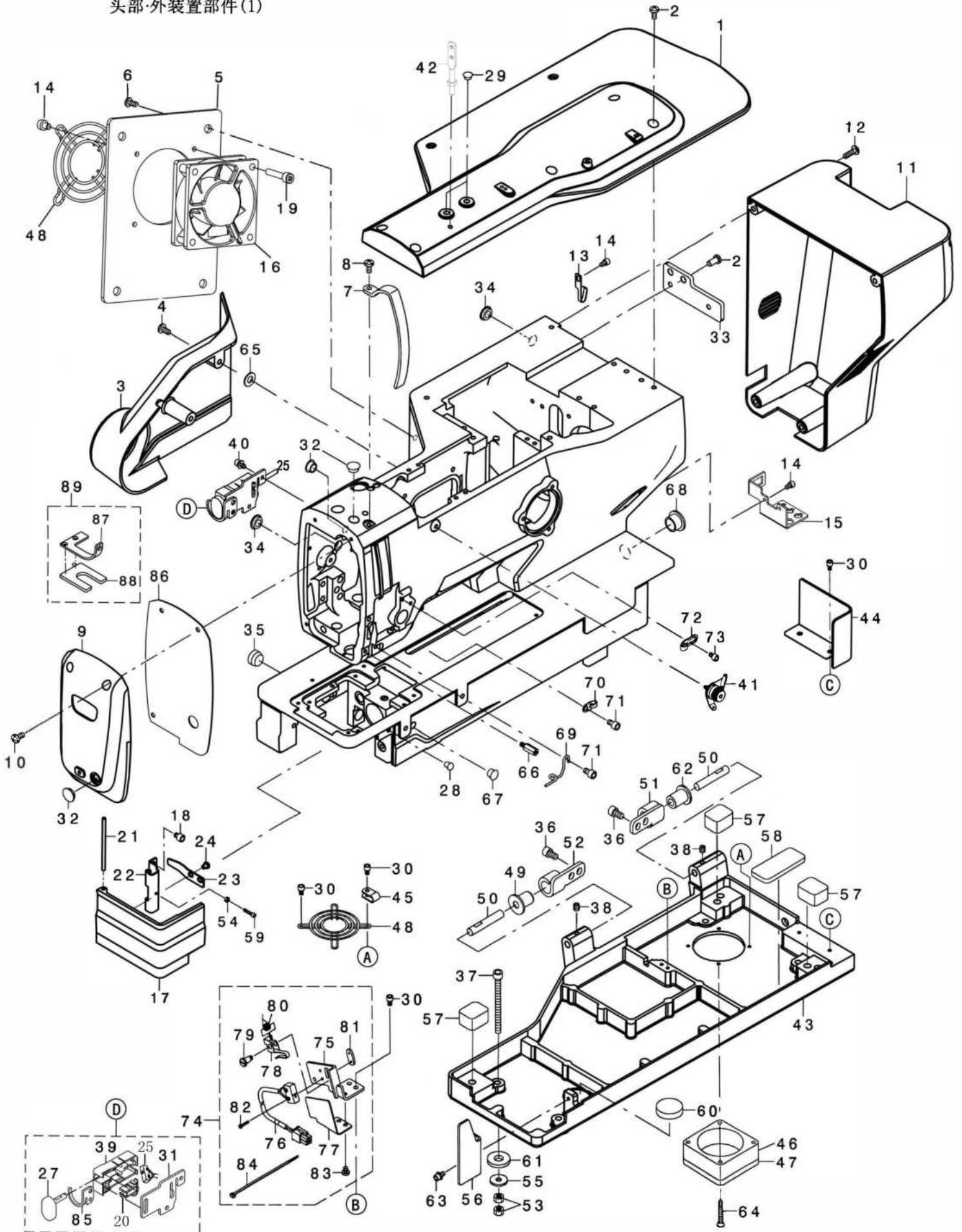

序号 NO	注解 Note	件号 Part NO.	名称	Description	数量 Qty
1	141301006(漆前)	930000142(漆后)	上盖板	UPPER COVER	1
2		413S11002	螺钉	SCREW	10
3	141301003(漆前)	930000141(漆后)	左盖板	LEFT COVER	1
4		413S11002	螺钉	SCREW	2
5	141312006(漆前)	930000140(漆后)	风扇安装板	LEFT COVER B	1
6		413S11002	螺钉	SCREW	4
7	41312002(漆前)	301285(漆后)	挑线杆保护板	THREAD TAKE UP LEVER COVER	1
8		413S11002	螺钉	SCREW	1
9	141301007(漆前)	930000139(漆后)	前盖板	FRONT COVER	1
10		413S11003	螺钉	SCREW	3
11		141311001	电控罩壳	ELECTRICALLY CONTROLLED SHELL	1
12		413S11003	螺钉M5×16	SCREW M5 L=16	4
13		41312003	油管固定架	LUBRICATING OIL WICK	1
14		S05115	螺钉M4×6	STOPPER SCREW M4 L=6	5
15		141312005	电控插头安装板	ELECTRIC CONTROL PLUG MOUNTING SEAT	1
16		141330041	机头风扇	FAN MOTOR	1
17	41301046(漆前)	304118(漆后)	防护板	HOOK OIL SHIELD COVER COMPL	1
18		413S13001	螺钉M5×6	HEXAGON SOCKET HEAD SCREW M5×6	2
19		S05063	螺钉	SCREW M4×25	2
20		41330027	导向滑块	GUIDE THE SLIDER	1
21		41326044	转向架销	IBOGIE PIN	1
22		41312151	转向架	IBOGIE	1
23		41312006	压板簧	PRESSURE PLATE SPRING	1
24		413S11017	螺钉	SCREW	1
25		141330045	急停开关传感器		0
26		-----			0
27		41330042	开关按钮	SWITCH BUTTON	1
28		41322008	橡胶塞	RUBBER PLUG	1
29		41322009	橡胶塞	PLUG D=7.5 L=3.5	2
30		S05115	螺钉M4×6	SCREW M=4 L=6	6
31		41312008	固定架	THE FIXED FRAME	1
32		41322012	橡胶塞	RUBBER PLUG	3
33		141301001	电控安装板	ELELECTRIC CONTROL MOUNTING SEAT	1
34		41322014	橡胶塞	RUBBER PLUG D=12.5 L=4	2
35		41322015	橡胶塞	PLUG	1
36	01	413S13005	螺钉M6×10	SCREW M=6 L=10	4
37		413S13006	螺栓M6×70	HEXAGON BOLT	4
38		413S14001	螺钉M6×6	SCREW M=6 L=6	2
39		41330041	开关	SWITCH	1
40		417S30034	螺钉M4×8	SCREW	2
41		4131301500	张力控制组件	PRE-TENSION CONTROLLER ASM	1
42	01	41313013	过线轴	THREAD GUIDE BAR	1
43		141301002	油盘	BED BASE	1
44		141311010	底座盖板	BED REAR COVER	1
45		41311001	线夹	CABLE CLAMP	1
46		141330042	油盘风扇	HEAD FAN MOTOR B ASS'Y	1
47		41311002	过滤器	FILTER	1
48		41312011	风扇挡板	FINGER GUARD	2
49	01	41303001	铰链套	HINGE BUSH	1
50		41326002	铰链销	HINGE PIN	2
51	01	41312012	铰链板	HINGE PLATE, A	1
52	01	41312013	铰链板	HINGE PLATE, B	1
53		205S16005	螺母M6	NUT M=6	8
54		N01013	螺母M3×0.5	NUT M3×0.5	1
55		41328001	垫片	WASHER 6.1×18.5×2	4
56	01	41311003	防油罩	OIL SHIELD	1
57		41322001	橡胶垫	RUBBER C	3
58		41322002	垫板	RUBBER D	1
59		413S14012	螺钉	SCREW	1
60		41322017	橡胶	Z STOPPER RUBBER	1
61		41322003	橡胶垫片	RUBBER CUSHION (B)	4
62	01	41322004	橡胶铰链	RUBBER HINGE	1
63	01	413S13008	螺钉M4×10	SCREW	1
64		S02090	螺钉M4×30	SCREW M4×0.7 L=30	2
65		41328002	垫片	CLOTH PLATE WASHER	2
66		413S30025	加长螺钉	VCS STUD A	1
67		41322011	橡胶塞	RUBBER PLUG	1
68		41322018	橡胶塞	RUBBER PLUG	1
69		41313001	过线钩	NEEDLE BAR THREAD GUIDE	1
70		41313002	左线钩	TAKE-UP THREAD GUIDE B	1
71		413S13010	螺钉M5×8	SCREW M5×0.8 L=8	2
72		41313003	右线钩	TAKE-UP THREAD GUIDE A	1
73		S05115	螺钉M4×6	SCREW M=4 L=6	1
74		4133000400	安全开关组件	SAFETY SWITCH ASS'Y	1
75		41312084	安全开关座	SAFETY SW BASE	1
76		141330046	感应器	SAFETY SWITCH SENSORS	1
77		41312085	安全开关盖板	SAFETY SWITCH COVER	1
78		40312132	安全开关臂	SAFETY SWITCH ARM SAFETY	1
79		413S20011	轴位螺钉	SWITCH ARM SHAFT SAFETY	1
80		40327024	安全开关弹簧	SWITCH SPRING	1
81		40312133	安全开关螺母	SAFETY SWITCH NUT	1
82		403S11050	螺钉	SCREW M=2 L=12	2
83		413S15004	螺钉	SCREW 9/64-40 L=4.5	2
84		40111005	固定带	CABLE BAND	1
85		41312009	防护架	PROTECTIVE FRAME	1
86		41322026	前盖板垫	FRONT COVER PAD	1
87		41312160	LED灯安装板	LED FITTING PLATE	1
88		14133005	LED照明灯	LED	1
89		14133000600	LED照明灯组件	LED ASS'Y	1
		NOTE(注解)	01... ACCESSORIE PART	附件	

变更记录/CHANGE LOG

序号 No.	件号 Part No.	名称	NAME OF PARTS	使用时间 Usage time period
42	41313013	过线轴	THREAD GUIDE BAR	-2023.7
	1421300100	上过线组件	UPPER WIRE ASSEMBLY	2023.8-
44	141301004	底座盖板	BED REAR COVER	-2023.9
	141311010	底座盖板	BED REAR COVER	2023.10-

2. FRAME & MISCELLANEOUS COVER COMPONENTS (2)

头部·外装置部件(2)

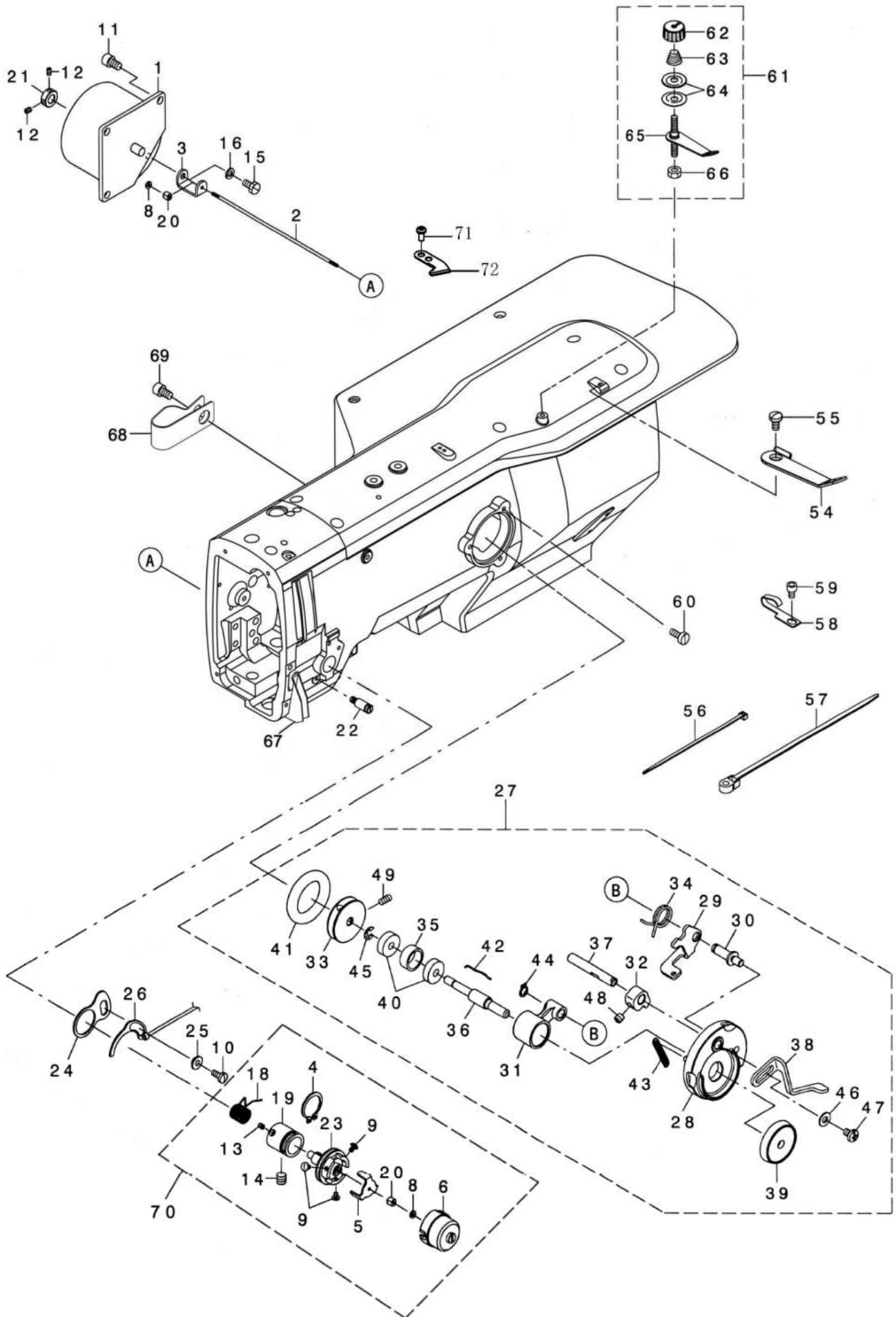

序号 NO	注解 Note	件号 Part NO	名称	Description	数量 Qty
1		41330072	夹线电磁铁	ASSY AT SOLENOID	1
2		41312014	拉杆	AT SHAFT	1
3		41312015	拉杆固定架	AT SHAFT HOLDER	1
4		40329004	卡簧	RETAINING RING	1
5		40312123	松线止动卡盘	DISK STOPPER	1
6		40303024	夹线器帽	DISK STOPPER HOLDER CAP	1
7		-----			0
8		413S16001	螺母	NUT	2
9		403S11048	螺钉	SCREW	3
10		403S11019	螺钉M4×8	SCREW M=4 L=8	1
11		413S13010	螺钉M5×8	SCREW M5×0.8 L=8	3
12		413S14004	定位环螺钉	SCREW	2
13		403S14015	螺钉	SCREW M3 L=4	1
14		413S14001	螺钉M6×6	SCREW M6 L=6	1
15		413S11023	螺钉	SCREW	1
16		W02002	弹簧垫片	SPRING WASHER	1
17		-----			0
18		40327019	弹簧	TAKE-UP SPRING	1
19		40303025	夹线器座	THREAD TENSION POST BASE	1
20		41329002	卡圈	THREAD TENSION SHAFT COLLAR	2
21		41303002	定位环	THRUST COLLAR	1
22		413S30009	缓线钩定位螺钉	UTT SUSPENSION SCREW 9	1
23		4131300400	紧线器组件	ASSY THREAD TENSION POST	1
24		41311004	导板	GUIDE PLATE	1
25		41328005	尼龙垫片	BUSHING	1
26		41312018	接触片	THREAD BREAK DETECTOR A	1
27		4133104100	绕线器组件	ASSY BTW	1
28		40301026	盖板	BTW BASE	1
29		40312125	控制板	BTW CAM PLATE	1
30		40302014	绕线定位轴	BTW BASE SHAFT	1
31		40304013	绕线转动曲柄	BTW SHAFT BASE	1
32		40310008	转动卡头	BTW CAM LEVER	1
33		40327026	绕线转动板	BTW WHEEL	1
34		40327023	弹簧	BTW TORSION SPRING	1
35		40308012	挡圈	BTW BEARING SPACER	1
36		41302012	绕线器轴	BTW SHAFT	1
37		41302013	梭心压杆轴	BTW LEVER SHAFT	1
38		41312087	梭心压杆	BTW LEVER	1
39		41328021	梭心垫片	BTW SPACER	1
40		40324015	轴承	BTW BEARING	2
41		40322030	O形圈	BTW WHEEL RUBBER	1
42		40327021	梭心弹簧	BOBBIN SPRING	1
43		40327022	弹簧	BTW SPRING	1
44		40329005	卡簧	RETAINING RING	1
45		40329006	卡簧	E-RING 4	1
46		40328038	垫片	WASHER 4.5×10×0.8	1
47		403S11052	螺钉	SCREW	1
48		403S14022	螺钉	SCREW	1
49		403S14023	绕线转动板螺钉	SCREW M4×8	2
50		14112020	垫圈	WASHER	1
51		-----			0
52		-----			0
53		-----			0
54		41313020	导线器	THREAD GUIDE	1
55		413S11008	过线板螺钉	SCREW 11/64-40 L=7.8	1
56		40111005	固定带	CABLE BAND	10
57		40311023	固定带	CABLE BAND	2
58		41312003	润滑油管固定片	LUBRICATING OIL WICK STOPPER	3
59		S05115	螺钉M4×6	SCREW M4 L=6	3
60		413S11004	螺钉M4×10	SCREW M4 L=10	3
61		4131302200	绕梭心夹线器组件	BOBBIN THREAD TENSION ASM	1
62		101S16019	塑料螺母	THREAD TENSION NUT	1
63		41327017	弹簧	THREAD TENSION SPRING	1
64		41313015	过线片	BOBBIN WINDER TENSION DISC	2
65		4131302300	过线销组件	BOBBIN THREAD TENSION ROD ASM	1
66		413S16012	螺母SM11/64 “×40	NUT 11/64-40	1
67		41312021	导线槽	THREAD GUIDE	1
68		41312089	线夹	CLAMP	1
69		413S13010	螺钉M5×8	SCREW M5 L=8	1
70		4131301900	夹线器组件	THREAD TENSION ASM	1
71		413S11022	螺钉	SCREW	2
72		11419001	割线刀	THREAD CUTTER	1

变更记录/CHANGE LOG

序号 No.	件号 Part No.	名称	NAME OF PARTS	使用时间 Usage time period
27	14133101800	割绕一体绕线器	ASSY BTW	-2022.12
	4133104100	绕线器组件	ASSY BTW	2023.1-
61	14131300100	绕梭心夹线器组件	BOBBIN THREAD TENSION ASM	-2023.2
	4131302200	绕梭心夹线器组件	BOBBIN THREAD TENSION ASM	2023.3-
71	413S11022	螺钉	SCREW	2023.3-
72	11419001	割线刀	THREAD CUTTER	2023.3-

3. MAIN SHAFT COMPONENTS

上轴部件

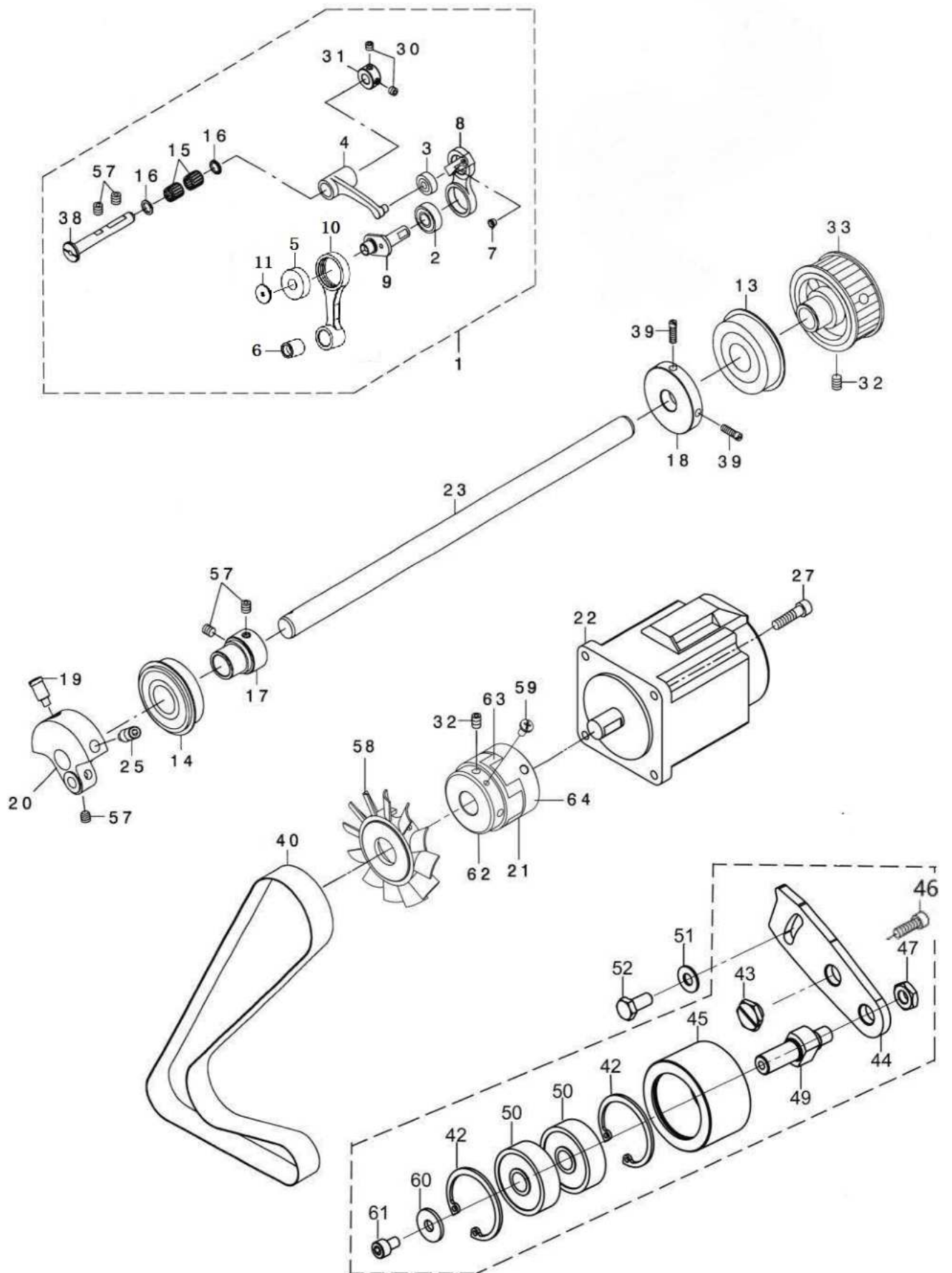

序号 NO	注解 Note	件号 Part NO.	名称	Description	数量 Qty
1		14133800300	挑线杆组件	THREAD_TAKE_UP_ASM	1
2		41324001	挑线曲柄轴承	BEARING	1
3		41324002	挑线连杆轴承	BEARING	1
4		41338001	挑线连杆	THREAD_TAKE_UP_CRANK	1
5		41324003	针杆连杆轴承	BUSHING	1
6		141303005	挑线杆铜套	BUSH	1
7		41313009	过线套	THREAD_PASS_BUSH	1
8		4133800200	挑线杆组件	LINK_TAKE_UP	1
9		41338003	挑线曲柄	NEEDLE_BAR_CRANK	1
10		141305013	针杆连杆	NEEDLE_BAR_CRANK_ROD	1
11		403S30011	螺钉	LEFT SCREW	1
12		S09103	螺钉M4×4	SET SCREW M4 L=4	1
13		41324004	上轴后轴承	BEARING	1
14		41324005	上轴前轴承	BEARING	1
15		41324006	滚针轴承	BEARING	2
16		40322025	封油垫片	BEARING_SUPPORT	2
17		41303005	轴承固定套	BEARING HOLDER	1
18		40335002	绕线轮	BOBBIN_WINDER_DRIVING_WHEEL	1
19		403S13007	固定螺钉	COUNTER_WEIGHT_SCREW	1
20		41304001	针杆曲柄	COUNTER_WEIGHT	1
21		4030102200	传动连接块组件	COUPLING	1
22		141333008	主轴伺服电机	AC_SERVO_MOTOR	1
23		41302001	上轴	MAIN_SHAFT	1
24		-----			
25		413S30012	螺钉M8×16	SCREW M8 L=16	1
26		-----			
27		114S13001	螺钉M5×20	SCREW M5 L=20	4
28		-----			
29		-----			0
30		114S14001	挡圈螺钉	SCREW	2
31		40308006	挡圈	THRUST_COLLAR	1
32		403S14005	连接块螺钉	SCREW M6 L=8	6
33		4133500100	上同步带轮组件	SPROCKET_A	1
34		-----			
35		-----			
36		-----			
37		-----			
38		41326004	挑线连杆轴	THREAD_TAKE_UP_CRANK_SHAFT	1
39		403S14008	绕线轮螺钉	SCREW M5 L=8	2
40		41335002	同步带	TIMING_BELT	1
41		-----			
42		41329003	卡簧	RETAINING_RING	2
43		1413NS16001	螺母	HINGE_SCREW	1
44		41312140	张紧轮安装板	IDLER_FIXED_PLATE	1
45		41303008	张紧轮	IDLER_PULLEY	1
46		S05040	螺钉	NUT	
47		422S16501	螺母M8	NUT M8	1
48		-----			
49		41305009	张紧轮连杆	IDLER_FIXED_ROD	1
50		41324007	轴承	BALL_BEARING	2
51		41328008	垫片	WASHER	1
52		413S12002	螺钉M6×14	SCREW M6 L=14	1
53		-----			
54		-----			
55		-----			
56		41328022	垫片	WASHER	1
57		413S14001	螺钉M6×6	SCREW M6 L=6	6
58		40311302	叶轮	FAN	1
59		413S13016	螺钉	SCREW	3
60		40228011	垫片	WASHER	1
61		413S13010	螺钉M5×8	SCREW M5 L=8	1
62		40301023	传动连接块	COUPLING_1	1
63		40322028	减震橡胶	DAMPING_RUBBER	1
64		40301024	传动连接块	COUPLING2	1

变更记录/CHANGE LOG

序号 No.	件号 Part No.	名称	NAME OF PARTS	使用时间 Usage time period
1	4133800100	挑线杆组件	THREAD TAKE UP ASM	-2020.6.29
	14133800300	挑线杆组件	THREAD TAKE UP ASM	2020.6.30-
43	1413NS16001	螺母	HINGE SCREW	2021.11-
46	S05040	螺钉	SCREW	2021.11-

4. HOOK DRIVING SHAFT COMPONENTS

下轴部件

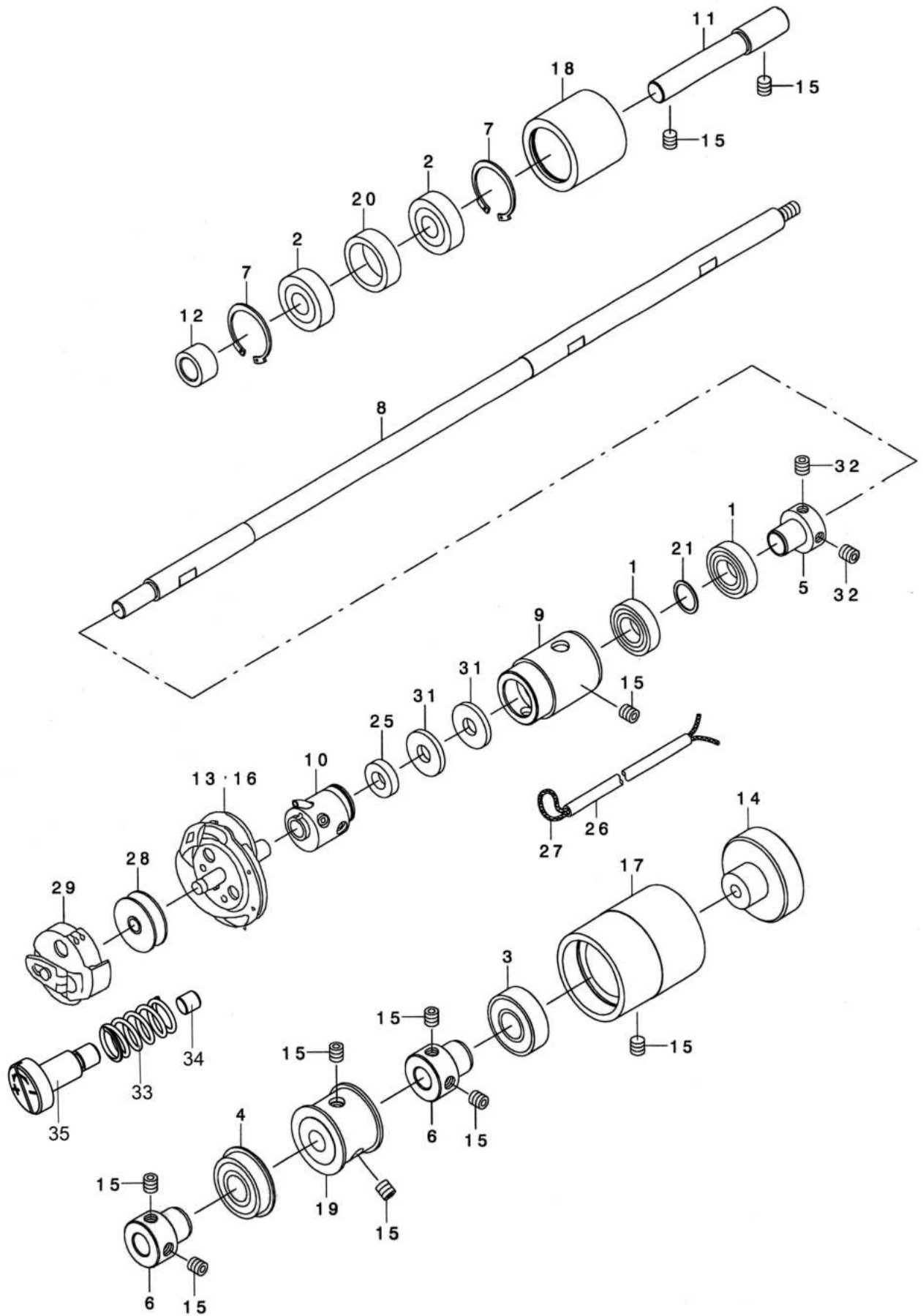

序号 NO	注解 Note	件号 Part NO.	名称	Description	数量 Qty
1		11424001	轴承	BEARING	2
2		41324009	轴承	BALL BEARING	2
3		41324010	轴承	BEARING	1
4		41324011	轴承	BEARING	1
5		41303010	轴承固定套	BEARING_SUPPORT	1
6		41303011	轴承固定套	BUSH	2
7		41329004	卡簧	RETAINING RING	2
8		41302002	下轴	HOOK_DRIVING_SHAFT	1
9		41303012	下轴前轴套	HOOK_DRIVING_SHAFT_METAL	1
10		4130301300	旋梭连接套组件	HOOK SLEEVE ASM	1
11		41335003	中同步带轮轴	INTERMEDIATE SPROCKET SHAFT	1
12		41303009	挡圈	INTERMEDIATE SPROCKET WASHER	1
13	01	41318001	旋梭(790)	HOOK COMPL	1
14		4131101100	手轮组件	CROWN KNOB	1
15		413S14001	螺钉M6×6	SCREW M6 L=6	10
16	02	41318002	旋梭(791K)	HOOK COMPL (K)	1
17		41303014	下轴后轴套	BEARING_SUPPORT	1
18		41335004	中同步带轮	SPROCKET_B	1
19		4133500600	下同步带轮组件	SPROCKET_C	1
20		41303015	垫圈	INTERMEDIATE SPROCKET RING	1
21		41328009	垫圈	WASHER	1
22		-----			0
23		-----			0
24		-----			0
25		41323002	油毡	FELT	1
26		12921005	油管	TUBE	1
27		40323013	油线	OIL WICK	1
28		4021800200	梭心	BOBBIN	1
29		41318003	梭壳	BOBBIN CASE ASM	1
30		41303016	油量控制架	PIPE	1
31		41323003	油毡	OIL FILTER	2
32		207S11042	螺钉	SCREW M5 L=5	2
33		41328035	控油弹簧	OIL CONTROL SPRING	1
34		41326039	调整杆	ADJUSTING_SHAFT	1
35		413S15002	旋梭油量调节螺钉	ADJUSTING OIL OF HOOK	1

NOTE (注解)

01... FOR 1790S
02... FOR 1790K

1790S用
1790K用

序号 NO	注解 Note	件号 Part NO.	名称	Description	数量 Qty
1		141333002	送布马达(大豪)	FEED MOTOR ASS'Y (DAHAO)	1
2		141330040	送布传感器(含线缆)	FEED SENSOR ASS'Y	1
3		40322025	封油垫片	BEARING SUPPORT	2
4		41312023	固定板	THROAT PLATE BASE COVER	2
5		41312024	送料步进电机固定架	MOTOR BRACKET	1
6		4133500700	送料后同步带轮组件	PULLEY B	1
7		4133500900	送料前同步带轮组件	PULLEY C	1
8		41326008	送料前同步带轮轴	SUPPORT SHAFT	1
9		41312025	固定板	TIMING BELT HOLDER	1
10		41302003	支架轴	FEED SHAFT	1
11		41302004	送布支架导向轴	FEED GUIDE SHAFT	1
12		4130400100	送布支架组件	FEED BASE ASM	1
13		41304002	送布支架	FEED BASE	1
14		41324014	送布支架轴承	SLIDE BEARING	3
15		-----	挡圈组件	THRUST COLLAR ASM	1
16		40308006	挡圈	THRUST COLLAR	1
17		114S14001	螺钉	SCREW	2
18		41312026	拖板	WORK CLAMP CARRIER	1
19		413S13026	螺钉组件	SCREW M3×10	1
20		S05115	螺钉M4×6	SCREW M4 L=6	4
21		413S13016	螺钉M4×8	SCREW M4×0.7 L=8	2
22		413S13017	螺钉M4×10	SCREW M4 L=10	6
23		413S13005	螺钉M6×10	SCREW M6 L=10	3
24		S05042	螺钉M6×22	SCREW M6 L=18	1
25		207S11042	螺钉	SCREW M5 L=5	3
26		413S14001	螺钉M6×6	SCREW M6 L=6	2
27		41335007	送布同步带	TIMING BELT	1
28		413S11009	螺钉M4×5	SCREW M4 L=5	4
29		4133001200	抬压脚组件	ASSY PBL GEAR MODULE	1
30		141333001	抬压脚步进电机(大豪)	CLAMP MOTOR ASS'Y (DAHAO)	1
31		41312028	压脚导向连接板	PBL FRONT LINK	1
32		41325001	压脚升降齿轮B	PBL GEAR S	1
33		41326009	齿轮轴	PBL GEAR SHAFT	1
34		41312029	压脚升降摆动板	PBL L LINK	1
35		41305002	压脚升降拉杆	PBL LONG ROD	1
36		-----			0
37		-----			0
38		413S13017	螺钉M4×10	SCREW M4 L=10	4
39		413S14003	螺钉M6×5	SCREW M6 L=5	5
40		413S200014	压脚升降摆动板螺钉	SHOULDER SCREW D8 H3.2	4
41		4132500200	压脚升降齿轮A组件	ASSY PBL GEAR L	1
42		14131200400	压脚电机安装板组件	ASSY PBL MOTOR BASE	1
43		41326010	压脚支架固定轴	PIN, SHORT	1
44		-----			0
45		41309005	滑轮	SLIDE ROLLER	1
46		41303018	衬套	COLLAR	1
47		41327004	压脚杆弹簧	PBL COLL SPRING	1
48		41327005	防护簧	PBL FINGER GUARD	1
49		41312032	压脚杆滑槽	PBL GUIDE	1
50		41312033	压脚前后送料导向板	PBL LIFTING PLATE	1
51		41303019	压脚杆套	PBL METAL	1
52		41304003	压脚杆升降支架	PBL POSITION BRACKET	1
53		41302005	压脚轴	PBLPRESSER BASE	1
54		41304004	滑轮支架	PBL ROLLER BASE	1
55		41326011	滑轮轴	PBL ROLLER SHAFT	1
56		-----			0
57		413S30003	弹簧调节螺母	PBL SPRING REGULATOR	1
58		141301005	压脚支架	PBL WORK CLAMP ARM	1
59		141302009	曲柄轴	PBL WORK CLAMP ARM SHAFT	1
60		-----			0
61		413S13016	螺钉M4×8	SCREW M4×0.7 L=8	1
62		413S13020	螺钉M4×16	SCREW M4×0.7 L=16	1
63		-----			0
64		413S11019	螺钉M5×10	SCREW M5×0.8 L=10	4
65		207S13009	螺钉M5×12	SCREW M5×0.8 L=12	4
66		413S14013	螺钉M5×6	SCREW M5 L=6	2
67		41312035	剪线板	UTT CLOSE CAM B	1
68		413S20001	压脚升降摆动板螺钉	SHOULDER SCREW D8 H3.2	1
69		413S14003	螺钉M6×5	SCREW M5 L=6	1
70		4131602000	压脚组件	WORK CLAMP CHECK HOLDER	1
71		41316018	压脚板座	WORK CLAMP CHECK HOLDER	1
72		41312109	压脚弹簧板	WORK CLAMP CHECK SPRING	2
73		41326035	压脚弹簧定位销	WORK CLAMP CHECK SPRING SET PI	2
74		41327020	压脚板座弹簧	WORK CLAMP CHECK HOLDER SPRING	1
75		413S11029	螺钉	SCREW 3/32-56 L=1.9	2
76		4131602200	压脚组件	WORK CLAMP CHECK HOLDER ASM	1
77		41316023	压脚板座	PRESSER FOOT	1
78		41312109	压脚弹簧板	WORK CLAMP CHECK SPRING	2
79		41326035	压脚弹簧定位销	WORK CLAMP CHECK SPRING SET PI	2
80		41327020	压脚板座弹簧	WORK CLAMP CHECK HOLDER SPRING	1
81		413S11029	螺钉	SCREW 3/32-56 L=1.9	2
82		41316025	压脚板	PRESSER	1
83		402S20002	压脚螺钉	HINGE SCREW D=7.94 H=2	1
84		41316017	压脚板	WORK CLAMP CHECK (2K)	1
85		207S14006	螺钉	SCREW M5 L=5	1
86		41312027	传感器定位板	SENSOR PLATE	1
87		41324006	滚针轴承	BEARING	2
88		41324013	轴承	BEARING	1
89		41328026	垫片	WASHER	2
90		4131602100	压脚组件	WORK CLAMP CHECK HOLDER ASM	1
91		4131602600	压脚组件	WORK CLAMP CHECK HOLDER ASM	1

6. NEEDLE BAR ROCKING COMPONENTS

针杆摇动部件

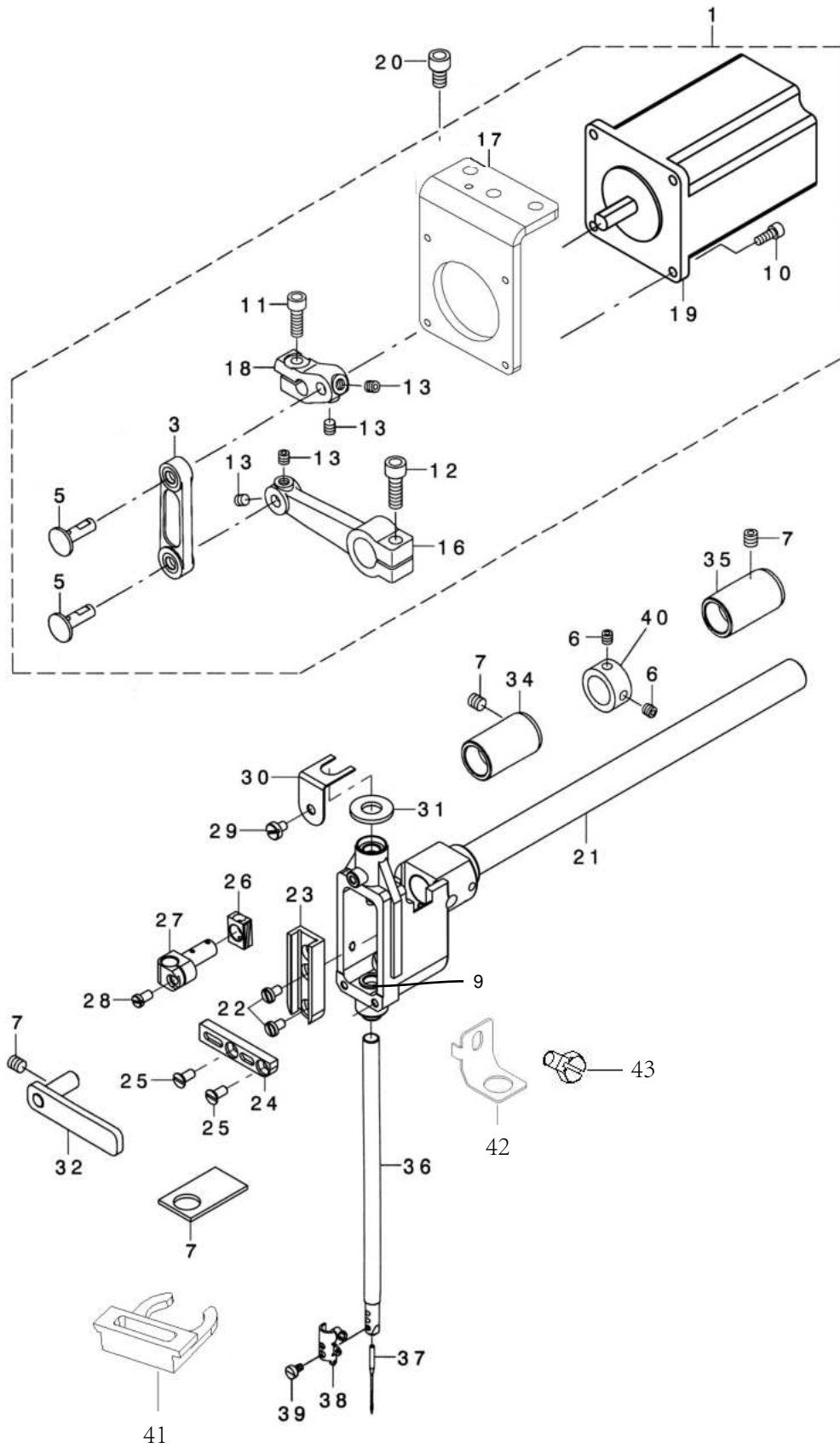

序号 NO	注解 Note	件号 Part NO.	名称	Description	数量 Qty
1		4133001500	摆轴驱动组件	ZIGZAG DRIVE FULL ASSY	1
2		-----			0
3		41305003	摆轴连杆	ZIGZAG ROD	1
4		-----			0
5		41326013	连接轴	JUNCTION SHAFT	2
6		207S11042	螺钉	SCREW M5 L=5	2
7		141323002	针杆架油毡	NEEDLE BAR CRANK FELT	4
8		-----			0
9		41303021	针杆衬套		2
10		-----			0
11		S05124	螺钉M5×16	SCREW M5 L=16	1
12		413S13018	螺钉M6×18	SCREW M6 L=18	1
13		207S14006	螺钉	SCREW M5 L=5	4
14		-----			0
15		-----			0
16		41304005	针杆摆动曲柄	ZIGZAG LEVER REAR	1
17		41301007	电机安装板	MOTOR_BASE	1
18		41304006	电机连接曲柄	MOTOR LEVER	1
19		141333003	针摆步进电机(大豪)	NEEDLE SWING MOTOR(DAHAO)	1
20		413S13023	螺钉M6×12	SCREW M6 L=12	3
21		14130102000	针杆架组件	NEEDLE BAR FRAME	1
22		S01002	螺钉 M4×6	SCREW M4 L=6	1
23		141309002	针杆导向板	GUIDE STRIP	1
24		141312014	针杆架压板	PRESSING PLATE	1
25		S02039	沉头螺钉M4	COUNTERSUNK SCREW M4 L=7	1
26		141309003	导向滑块	SLIDING BLOCK	1
27		141304008	针杆连接杆	NEEDLE BAR CONNECTION	1
28		413S11010	针杆连接杆螺钉	SCREW	1
29		413S11017	螺钉M4	NEEDLE BAR FRAME ASSY	1
30		141312015	油毡压板	NEEDLE BAR FRAME	1
31		141323001	针杆架油毡	NEEDLE BAR METAL	1
32		41312042	针杆架压板	SUPPORT_SHAFT	1
33		-----			
34		41303022	摆轴前套	PLATE ASM BUSHING	1
35		41303023	摆轴后套	BUSHING REAR	1
36		41302007	针杆	NEEDLE BAR	1
37		40217002	机针	NEEDLE DP×5 #12	1
38		41313010	面线导线器	NEEDLE BAR BOBBIN THREAD GUIDE	1
39		413S11011	螺钉M3×5	SCREW M3 L=5	1
40		41308003	摆轴挡圈	THRUST COLLAR D=15 W=11	1
41		141311009	线毛挡片	BAFFLE	1
42		141312030	针杆衬套压片	PIN ROD BUSHING PRESSING	1
43		413S12004	螺钉M4×7	SCREWM4×7	1

变更记录/CHANGE LOG

序号 No.	件号 Part No.	名称	NAME OF PARTS	使用时间 Usage time period
21	4130200600	摆轴组件	ZIGZAG LEVER REAR	-2020.6
	14130102000	针杆架组件	NEEDLE BAR FRAME	2020.7-
	41305004	针杆连杆	NEEDLE BAR ROD	-2020.6
	4130100900	针杆架组件	NEEDLE BAR FRAME ASSY	-2020.6
	41326018	针杆架连接轴	SUPPORT SHAFT	-2020.6
23	141309002	针杆导向板	GUIDE STRIP	2020.7-
24	141312014	针杆架压板	PRESSING PLATE	2020.7-
30	141312015	油毡压板	NEEDLE BAR FRAME	2020.7-
27	41304007	针杆连接杆	NEEDLE BAR CONNECTION	-2020.6
	141304008	针杆连接杆	NEEDLE BAR CONNECTION	2020.7-
26	41309006	针杆架滑块	SQUARE BLOCK	-2020.6
	141309003	导向滑块	SLIDING BLOCK	2020.7-
7	141323002	针杆架油毡	NEEDLE BAR CRANK FELT	2020.7-
31	141323001	针杆架油毡	NEEDLE BAR METAL	2020.7-
41	141311009	线毛挡片	BAFFLE	2023.4-
42	141312030	针杆衬套压片	PIN ROD BUSHING PRESSING	2023.6-

7. NEEDLE THREAD TRIMMER COMPONENTS

上剪线部件

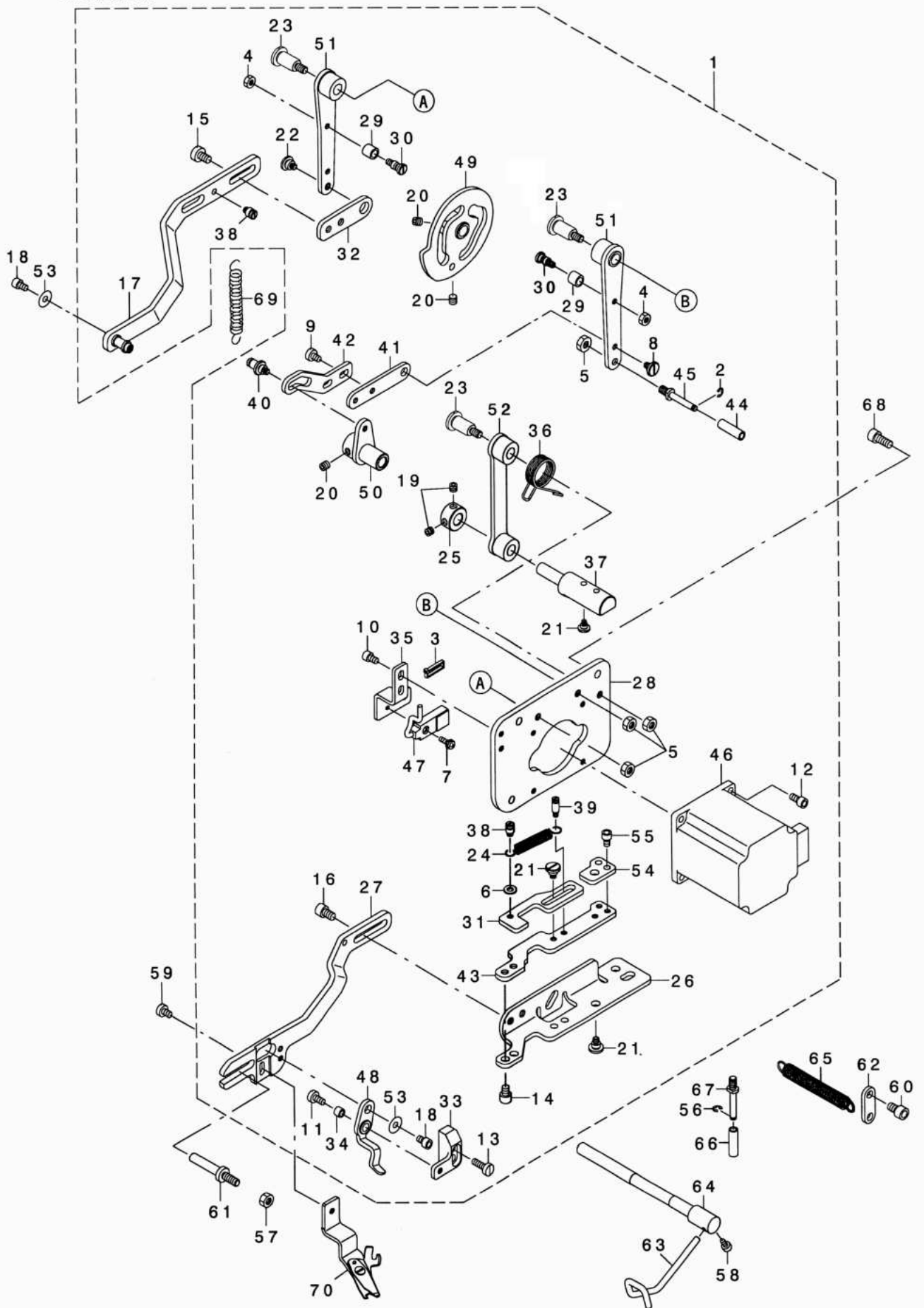

序号 NO	注解 Note	件号 Part NO.	名称	Description	数量 Qty
1		4131900100	剪面线组件	ASSY_U TT_MODULE_B	1
2		H05002	E形卡簧	E-RING 3	1
3		40111005	固定带	CABLE BAND	1
4		413S16003	螺母 M4	NUT M4	2
5		403S16006	螺母 M5	NUT M5	4
6		41328010	垫片	WASHER 4.3×9×0.8	1
7		413S13026	螺钉M3×10	SCREW M3×10	1
8		413S20003	固定板连接螺钉	SHOULDER SCREW D6 H2.6	1
9		413S11017	螺钉M4×6	SCREW M4 L=6	2
10		413S13003	螺钉M4×6	SCREW M4 L=6	2
11		403S11019	螺钉M4×8	SCREW M4 L=8	1
12		413S13016	螺钉M4×8	SCREW M4×0.7 L=8	4
13		413S12003	螺钉M4×12	SCREW M4 L=12	2
14		413S13001	螺钉M5×6	HEXAGON SOCKET HEAD SCREW M5×6	2
15		413S11018	螺钉M5×8	SCREW M5 L=8	2
16		413S13010	螺钉M5×8	SCREW M5×0.8 L=8	2
17		4131204400	开剪连杆组件	ASSY UTT RELEASE ARM B	1
18		S05115	螺钉M4×6	SCREW M4 L=6	2
19		207S11042	螺钉M5×4	SCREW M5 L=4	2
20		207S11042	螺钉	SCREW M5 L=5	4
21		413S30014	剪线导向板调节螺钉	SHOULDER SCREW D6 H3.2	4
22		413S20004	剪线连接板螺钉	SHOULDER SCREW D8 H4	1
23		413S20005	剪线曲柄螺钉	SHOULDER SCREW D8 15	3
24		41327006	导向板弹簧	SPRING	1
25		41308004	剪线支架连接销挡圈	THRUST COLLAR D=8 W=9	1
26		41312039	剪线支架	UTT_ARM_A	1
27		41312040	剪刀架	UTT_ARM_B	1
28		41312041	剪线电机安装板	UTT_BASE_PLATE	1
29		41303024	滚柱	UTT_CAM_ROLLER	2
30		413S30015	滚子连接螺钉	UTT_CAM_ROLLER_SHAFT	2
31		41312091	剪刀进退导向板	UTT_RATCH_PLATE_B	1
32		41312043	剪线连接板	UTT_RELEASE_ARM_A	1
33		41304008	开剪驱动板安装座	UTT_RELEASE_LEVER_BASE	1
34		41303025	连接滚子	UTT_RELEASE_LEVER_SHAFT	1
35		41312044	传感器安装板	UTT_SENSOR_BASE	1
36		41327007	扭簧	UTT_SUPPORT_ARM_SPRING	1
37		41326021	剪线支架连接轴	UTTSUPPORT_SHAFT	1
38		413S30016	螺钉	UTT_SUSPENSION_SCREW_4	2
39		413S30009	缓线钩定位螺钉	UTT_SUSPENSION_SCREW_9	1
40		413S30018	缓线连接销	UTT_SUSPENSION_SHOULDER_SCREW	1
41		41312045	缓线钩连接板	UTT_THREAD_PULLING_LINK_A	1
42		41312046	缓线钩驱动板	UTT_THREAD_PULLING_LINK_B	1
43		41312047	剪刀进退固定板	UTT_X-CAM	1
44		41303026	滚柱	UTT_Y-DRIVE_ROLLER	1
45		41326032	滚轴	UTT_Y-DRIVE_SHAFT	1
46		141333004	剪面线步进电机(大豪)	UT TRIM MOTOR ASS'Y(DAHAO)	1
47		141330038	面剪传感器(含线缆)	UT TRIM SENSOR ASS'Y	1
48		4131205500	开剪驱动板组件	ASSY_U TT_RELEASE_LEVER_B	1
49		4131205700	剪线凸轮组件	ASSY_U TT_CAM	1
50		4130401100	缓线钩连接曲柄组件	ASSY_U TT_THREAD_PULLING_ARM	1
51		4130401200	缓线钩导向曲柄组件	ASSY_U TT_CAM_ARM	2
52		4130401300	剪线连接曲柄组件	ASSY_U TT_SUPPORT_ARM	1
53		41328012	垫圈	PLAIN WASHER 4.3×12×1	2
54		41312088	限位板	UTT_RATCH_STOPPER	1
55		413S13003	螺钉M4×6	SCREW M4 L=6	2
56		H05002	E形卡簧	E-RING 3	1
57		413S16004	螺母M5	NUT M5	1
58		413S13003	螺钉M4×6	SCREW M4 L=6	1
59		413S13003	螺钉M4×6	SCREW M4 L=6	1
60		413S13010	螺钉M5×8	SCREW M5×0.8 L=8	1
61		41326034	压脚导向轴	UTT_GUIDE_SHAFT_B	1
62		41312053	连接板	UTT_SUSPENSION_PLATE	1
63		41313011	缓线钩	UTT_THREAD_PULLING_LEVER	1
64		41302008	缓线钩轴	UTT_THREAD_PULLING_SHAFT	1
65		41327009	剪线弹簧	UTT_TRIMMER_CLOSE_SPRING	1
66		41303026	滚柱	UTT_Y-DRIVE_ROLLER	1
67		41326032	剪刀控制轴	UTT_Y-DRIVE_SHAFT	1
68		207S13009	螺钉M5×12	SCREW M5×0.8 L=12	3
69		41327008	缓线钩复位弹簧	BUTTON_SUPPORT_LEVER_SPRING	1
70		4131900200	上剪线刀组件	ASSY_U TT_TRIMMER	1

8. BOBBIN THREAD TRIMMER COMPONENTS

下剪线部件

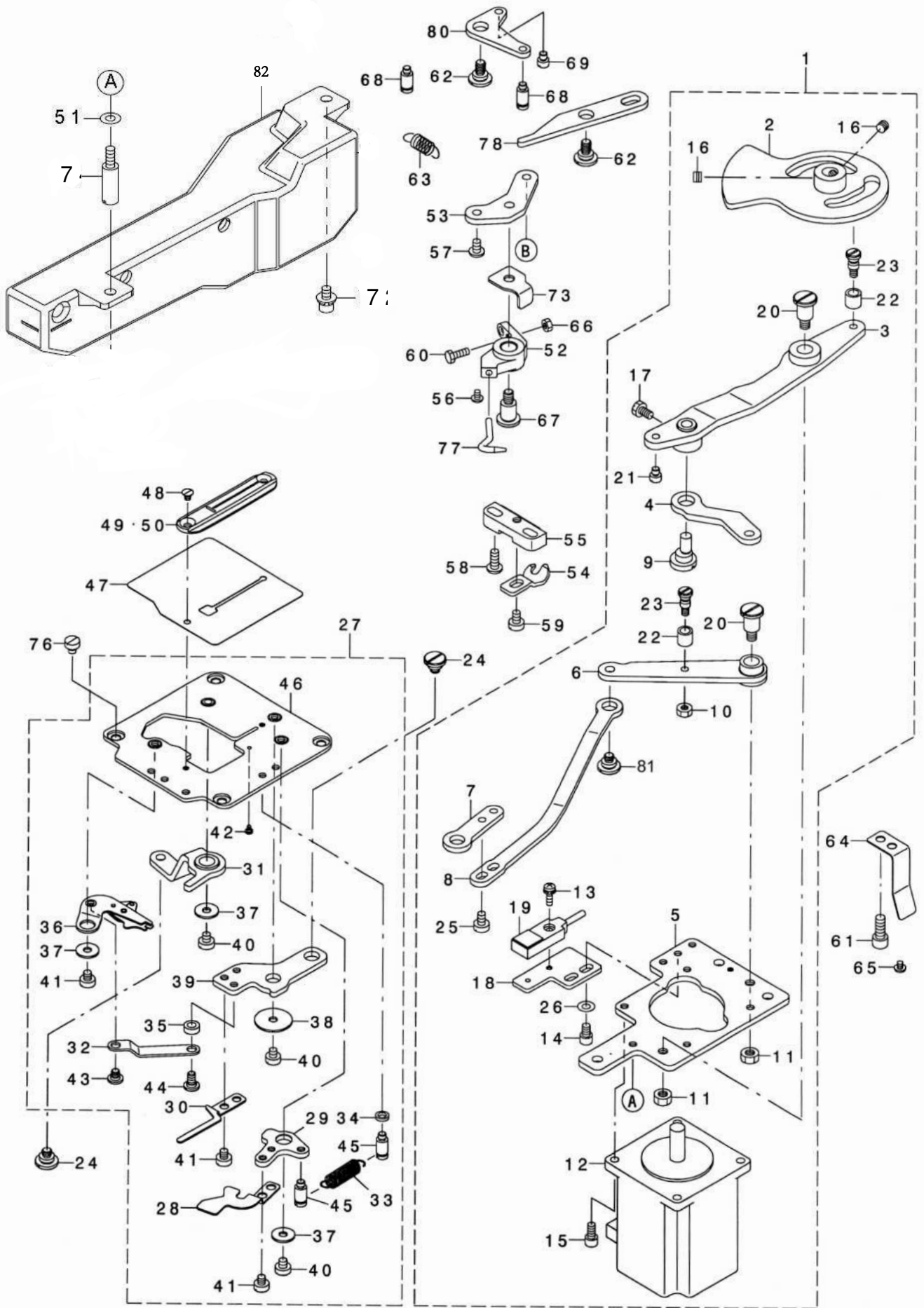

序号 NO	注解 Note	件号 Part NO.	名称	Description	数量 Qty
1		4133002000	剪底线组件	BTT DRIVE UNIT	1
2		4131206300	剪底线凸轮组件	ASSY BTT DRIVE CAM	1
3		4130500600	剪底线连杆组件	ASSY BTT DRIVE LEVER	1
4		41312056	剪底线连杆	BTT DRIVE LINK	1
5		41312057	底线电机安装板	BTT DRIVE UNIT BASE	1
6		4130401400	剪底线导向曲柄组件	ASSY BTT RELEASE LEVER	1
7		41312059	剪刀调节板	BTT RELEASE LINK F	1
8		41312060	剪底线导向曲柄连杆	BTT RELEASE LINK R	1
9		41326023	偏心轴销	LINK ROD	1
10		N01001	螺母M4	NUT M4	1
11		403S16006	螺母M5	NUT M5	2
12		141333005	剪底线步进电机	LT TRIM MOTOR ASS'Y	1
13		413S13026	螺钉M3×10	SCREW M3×10	1
14		S05115	螺钉M4×6	SCREW M4 L=6	2
15		413S13016	螺钉M4×8	SCREW M4×0.7 L=8	4
16		207S11042	螺钉M5×5	SCREW M5 L=5	2
17		413S12004	螺钉M4×7	SCREW	1
18		41312061	传感器安装板	SENSOR FITTING PLATE BT	1
19		141330039	底剪传感器(含线缆)	LT TRIM SENSOR ASS'Y	1
20		413S20006	轴位螺钉	SHOULDER SCREW D8 H10	2
21		413S30019	止动销	STOPPER PIN	1
22		41303024	滚柱	UTT CAM ROLLER	2
23		413S30015	滚子连接销	UTT CAM ROLLER SHAFT	2
24		413S20007	轴位螺钉	SHOULDER SCREW D8 H2.9	2
25		413S11017	螺钉M4×6	SCREW M4 L=6	2
26		41328010	垫圈	WASHER 4.3×9×0.8	2
27		4131500800	针板组件	THROAT PLATE BASE UNIT	1
28		41312062	剪线器压板	BT CLAMP B	1
29		41312063	固定板	BT CLAMP LEVER	1
30		41312064	底线导线器	BT PULLER B	1
31		4131207500	剪刀控制板组件	ASSY BT RELEASE ARM	1
32		41312066	传动连接杆	BT TRIMER LINK	1
33		41327010	弹簧	CLAMP SPRING	1
34		41328011	垫圈	WASHER	1
35		41308005	垫圈	WASHER	1
36		4131900300	下剪线刀组件	BT TRIMER	1
37		41328013	垫圈	PLAIN WASHER 4.3×12×1	3
38		41328014	垫圈	WASHER 4.5×20×1	1
39		41312070	剪底线传动板	BTT LEVER	1
40		413S11013	螺钉	SCREW M4 L=4	3
41		413S11013	螺钉M4×4	SCREW M4 L=4	5
42		413S11014	螺钉	HINGE SCREW	1
43		413S20008	轴位螺钉	SHOULDER SCREW D5 H1.6	1
44		413S20009	轴位螺钉	SHOULDER SCREW D5 H1.6	1
45		413S30020	挂簧螺钉	SUSPENSION SCREW	2
46		4131206800	剪线组件安装板	ASSY THROAT PLATE BASE	1
47		41312067	防油板	OIL SHIELD	1
48		-----	-----	-----	-
49	01	41315007	针板	THROAT PLATE(1790S5)	1
50	02	41315002	针板	THROAT PLATE(1790K5)	1
51		41328023	垫圈	WASHER M4	2
52		41304009	下挡线器座	PICKER BASE	1
53		41312072	下挡线器连接板	PICKER BASE FITTING PLATE	1
54		41312073	旋梭定位钩	STOPPER A	1
55		41304010	定位钩安装板	BOBBIN CASE POSITIONING PLATE	1
56		413S11022	螺钉M3×4	SCREW M3 L=4	1
57		413S13003	螺钉M4×6	SCREW M4 L=6	1
58		413S11024	螺钉M4×10	SCREW M4 L=10	2
59		413S11017	螺钉M4×6	SCREW M4 L=6	1
60		413S12003	螺钉M4×12	SCREW M4 L=12	1
61		413S13010	螺钉M5×8	SCREW M5×0.8 L=8	3
62		413S20013	轴位螺钉	SHOULDER SCREW D8 H2.9	2
63		41327011	弹簧	PICKER SPRING	1
64		41330017	安全开关板	SAFETY SWITCH PRESSING PLATE	1
65		413S11015	螺钉	SCREW	1
66		N01001	螺母M4	NUT M4	1
67		413S20006	轴位螺钉	SHOULDER SCREW D8 H10	1
68		413S30020	挂簧螺钉	SUSPENSION SCREW	2
69		413S30019	止动销	STOPPER PIN	1
70		-----	-----	-----	0
71					1
72		413S13008	螺钉M4×8	SCREW	2
73		41312075	止动板	PICKER BASE SCREW	1
74		413S30021	螺钉	SCREW	1
75		413S30007	螺钉	SCREW	1
76		413S11013	螺钉M4×4	SCREW M4 L=4	4
77		41313012	下挡线器	PICKER	1
78		41312076	下挡线传动杆	PICKER ACTUATING LEVER	1
79		413S13003	螺钉M4×6	SCREW M4 L=4	3
80		41312071	下挡线传动板	PICKER ACTUATING L LINK	1
81		413S20016	轴位螺钉	SHOULDER SCREW D8 H2.9	1
82		141311007	油盒	OIL TANK ASM	1
83					1

NOTE (注解) 01. . FOR 1790S 1790S用
02. . FOR 1790K 1790K用

变更记录/CHANGE LOG

序号 No.	件号 Part No.	名称	NAME OF PARTS	使用时间 Usage time period
82	4131101400	油盒组件	OIL TANK ASM	-2021.3
	141311007	油盒	OIL TANK ASM	2021.4-
	41312074	油盒安装板	OIL TANK PLATE	-2021.3
	413S30007	螺钉	SCREW	-2021.3

9. CLOTH CUTTING KNIFE COMPONENTS

切刀部件

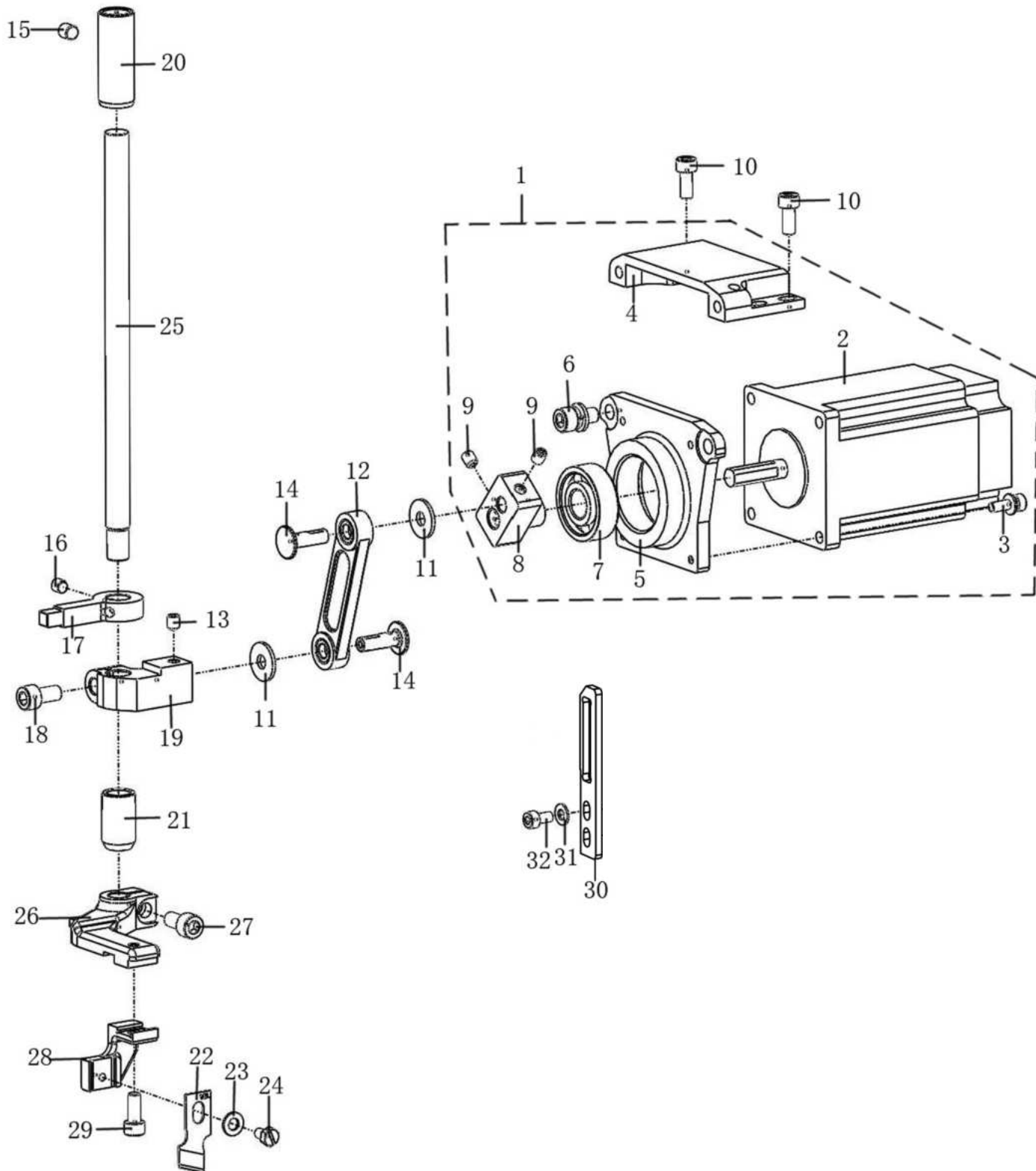

序号 NO	注解 Note	件号 Part NO.	名称	Description	数量 Qty
1		-----	切刀电机组件	KNIFE MOTOR ASSY	1
2		141333006	切刀电机	KNIFE MOTOR	1
3		417S30034	螺钉M4×14	SCREW M4 L=14	4
4		41301040	切刀电机安装上座	KNIFE MOTOR HIGHER BASE	1
5		41301041	切刀电机安装座	KNIFE MOTOR BASE	1
6		421S13029	螺钉M6×12	SCREW M6 L=12	2
7		41324016	轴承（6201Z）	BEARING	1
8		41303045	轴承连接套	KNIFE DRIVING BLOCK	1
9		413S14013	螺钉M5×6	SCREW M5 L=6	3
10		413S13019	螺钉M5×12	SCREW M5 L=12	4
11		41728004	垫片	WASHER 6×16×1.5	2
12		4130501000	切刀连杆组件	KNIFE DRIVING LINK ASSY	1
13		413S14013	螺钉M5×6	SCREW M5 L=6	1
14		41326013	连接轴A	JUNCTION SHAFT A	2
15		413S14001	螺钉M6×6	SCREW M6 L=6	1
16		207S11042	螺钉	SCREW	2
17		41304019	切刀导向	KNIFE GUIDE	1
18		413S13023	螺钉M6×12	SCREW M6 L=12	1
19		41304022	切刀杆支架	KNIFE BAR BRACKET	1
20		41303039	切刀杆上衬套	KNIFE BAR BUSHING	1
21		41303040	切刀杆下衬套	KNIFE BAR LOWER BUSHING	1
22		40219009	刀片1/2 "	KNIFE 1/2	1
23		41328010	垫圈	WASHER 4.5×9×0.8	1
24		L02003	螺钉M4×7	SCREW M4 L=7	1
25		41302009	切刀轴	KNIFE BAR	1
26		41304011	切刀杆座	KNIFE BAR BASE	1
27		413S13023	螺钉M6×12	SCREW M6 L=12	1
28		41304014	切刀安装座	KNIFE FITTING BASE	1
29		413S13019	螺钉M5×12	SCREW M5 L=12	1
30		401203	支撑导向板	SUPPORT GUIDE	1
31		41328010	垫片	WASHER 4.5×12×1	2
32		413S13016	螺钉M4×8	SCREW M4 L=8	2

变更记录/CHANGE LOG

序号 No.	件号 Part No.	名称	NAME OF PARTS	使用时间 Usage time period
31	41328012	垫片	WASHER	-2023.11
	41328012	垫片	WASHER	2023.11-
33	413S13013	螺钉M6×25	SCREW	-2023.11
34	141304009	切刀导向座	CUTTER GUIDE SEAT	-2021.11

10. TABLE COMPONENTS

台板部件

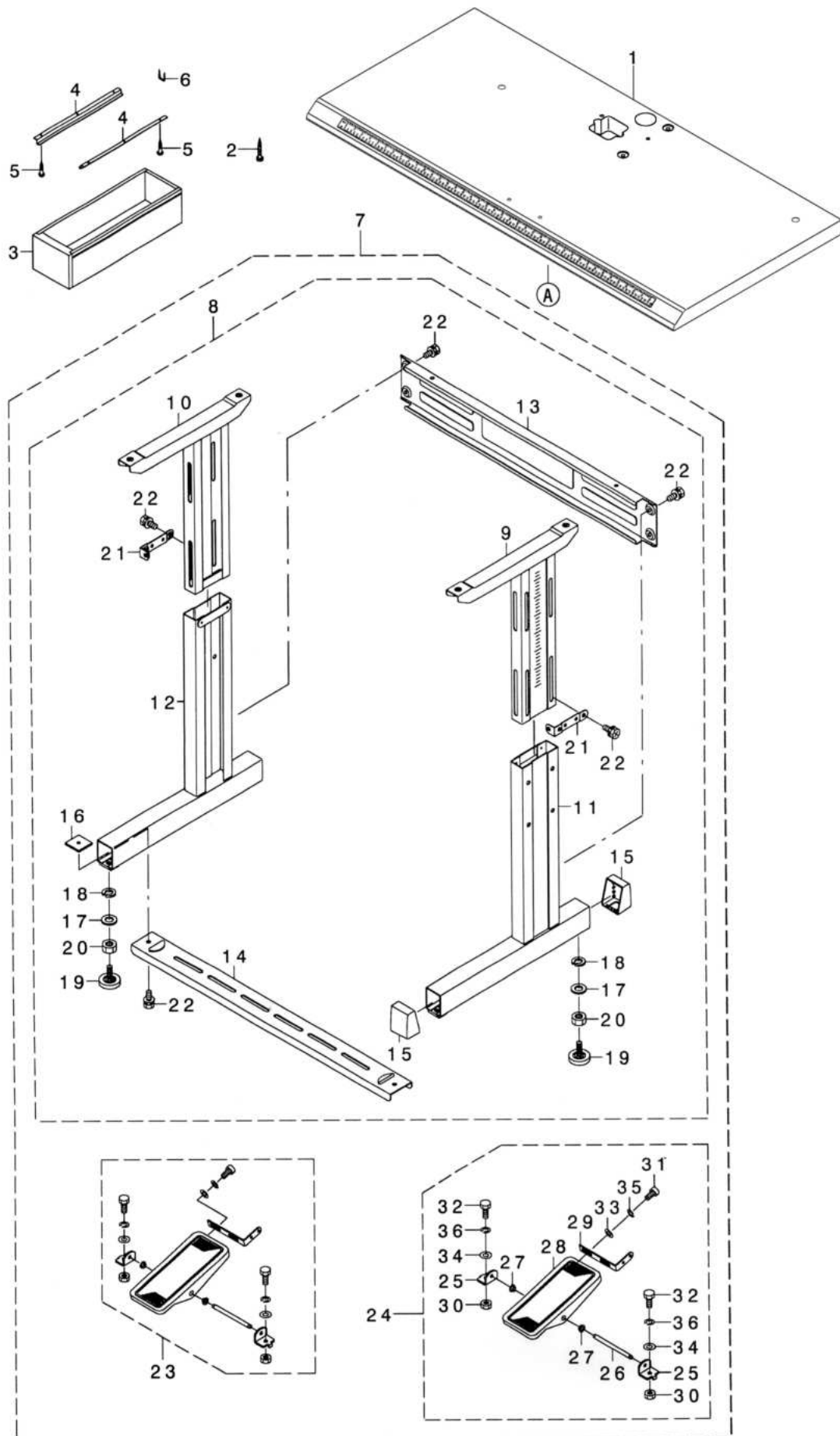

序号 NO	注解 Note	件号 Part NO.	名称	Description	数量 Qty
1		41332001	台板	TABLE	1
2		-----	自攻螺钉	TAPPING SCREW M5×35	4
3		-----	抽屉	DRAWER	1
4		-----	抽屉支架	DRAWER SUPPORT	2
5		-----	木螺钉	WOOD SCREW D=3.1 L=16	6
6		-----	抽屉挡板	DRAWER STOPPER	1
7		702052	桌脚部分	T-STAND COMPL	1
8		-----	桌脚组件	T-STAND ASM.	1
9		-----	右桌脚上支架	UPPER STAND ASM., RIGHT	1
10		-----	左桌脚上支架	UPPER STAND ASM., LEFT	1
11		-----	右桌脚下支架	LOWER LEG, RIGHT	1
12		-----	左桌脚下支架	LOWER LEG, LEFT	1
13		-----	桌脚横撑	STAND SIDE SUPPORT	1
14		-----	桌脚横撑	STAND SIDE SUPPORT	1
15		-----	橡胶套	RUBBER CAP	4
16		-----	螺母	NUT	2
17		-----	垫片	WASHER M12	4
18		-----	弹簧垫片	SPRING WASHER 12.5×21.5×3	4
19		-----	带垫调节螺钉	ADJUSTING SCREW ASM. WITH CAP	4
20		-----	螺母M12	NUT M12	1
21		-----	调节压板	UPPER STAND PLATE	2
22		-----	螺钉	WASHER HEXAGONAL BOLT	12
23		-----	踏板组件	Z-STAND PEDAL ASM	1
24		-----	踏板组件	Z-STAND PEDAL ASM	1
25		-----	踏板支架	PEDAL SHAFT BRACKET	2
26		-----	踏板连接轴	PEDAL CONNECTING ROD	1
27		-----	踏板轴衬	PEDAL BUSHING	2
28		-----	踏板	PEDAL ASM.	1
29		-----	踏板调节板	PEDAL ADJUSTING PLATE	1
30		-----	螺母	NUT M8	2
31		-----	螺钉M6×12	SCREW M6 L=12	2
32		-----	螺钉M8×20	SCREW M8 L=20	2
33		-----	垫片	WASHER 6.7×13×1	2
34		-----	垫片	WASHER 8.7×18×1.6	4
35		-----	弹簧垫片	SPRING WASHER 6.2×11.4×1.2	2
36		-----	弹簧垫片	SPRING WASHER 8.6×15×1.4	2

11. CONTROL BOX COMPONENTS
控制箱关系

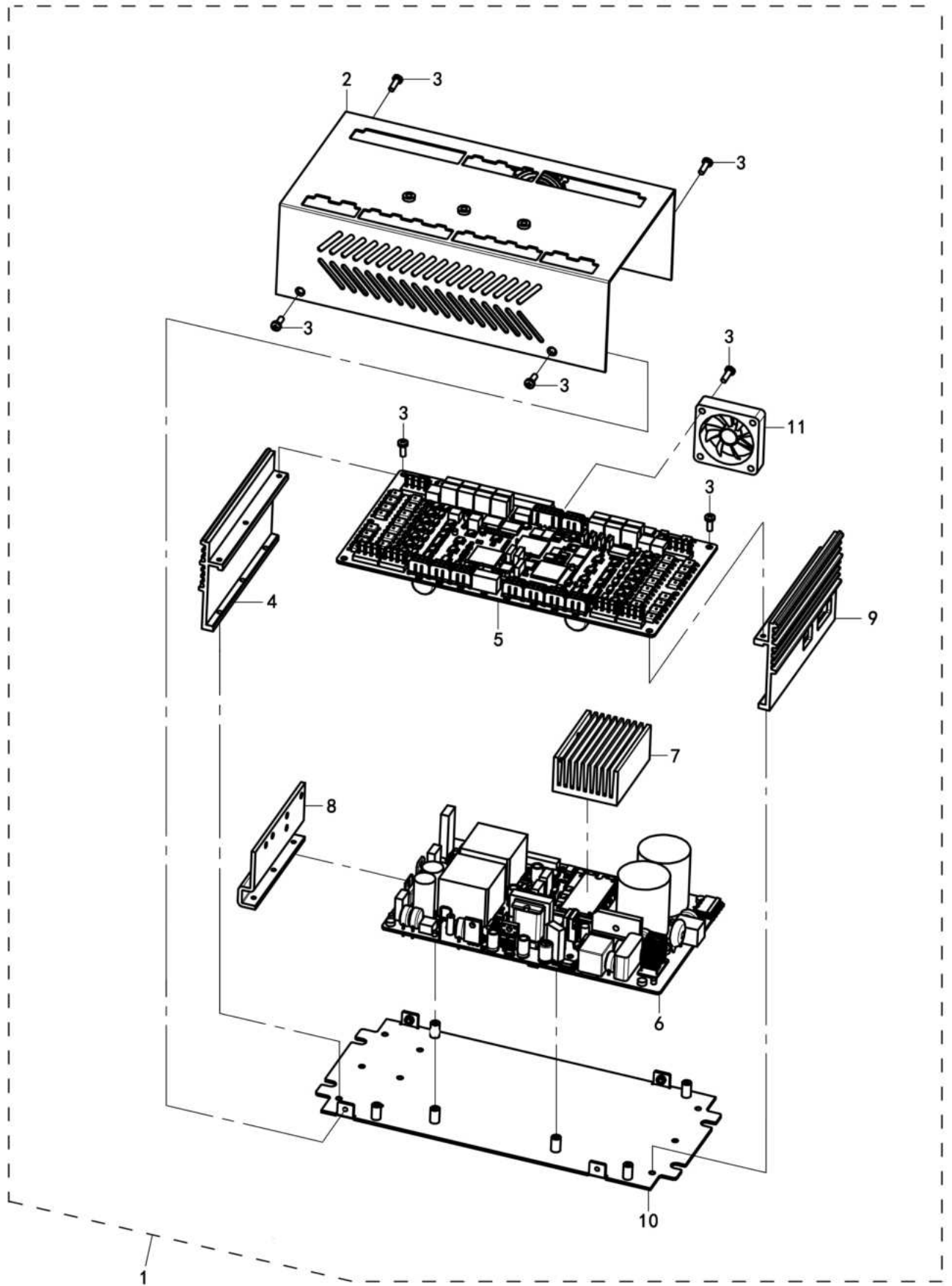

序号 NO	注解 Note	件号 Part NO.	名称	Description	数量 Qty
1		14133000300	大豪电控	CONTROL OF DAHAO	1
2		-----	盖板	COVER PLATE	1
3		-----	螺钉	SCREW	12
4		-----	前散热板	FRONT COOLING PLATE	1
5		14133004300	电路板1	PCB 1	1
6		14133004400	电路板2	PCB 2	1
7		-----	K16Q小散热器	K16Q SMALL RADITOR	1
8		-----	散热挡板	HEAT DISSIPATION BAFFLE	1
9		-----	后散热板	REAR COOLING PLATE	1
10		-----	底座板	BASE PLATE	1
11		811136	风扇	FAN MOTOR	1

12. OPERATION BOX COMPONENTS
操作面板部件

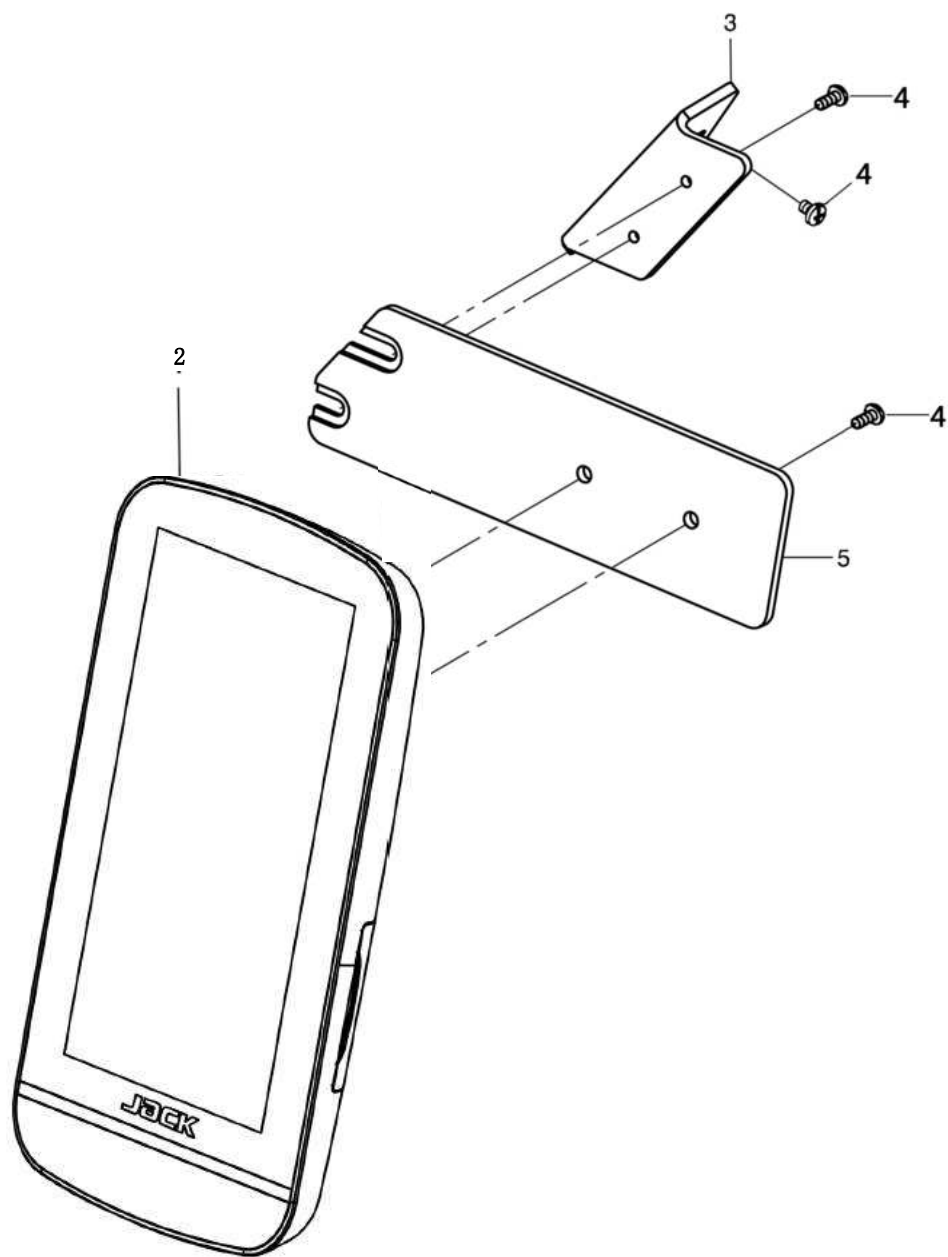

序号 NO	注解 Note	件号 Part NO.	名称	Description	数量 Qty
2		14133000400	大豪触摸屏	OPERATION PANEL OF DAHAO	1
3		141312001	面板支架1	OPERATION PANEL HOLDER 1	1
4		403S11013	螺钉M4×8	SCREW M4 L=8	6
5		141312002	面板支架2	OPERATION PANEL HOLDER 2	1

13. ACCESSORIE PART COMPONENTS

附件

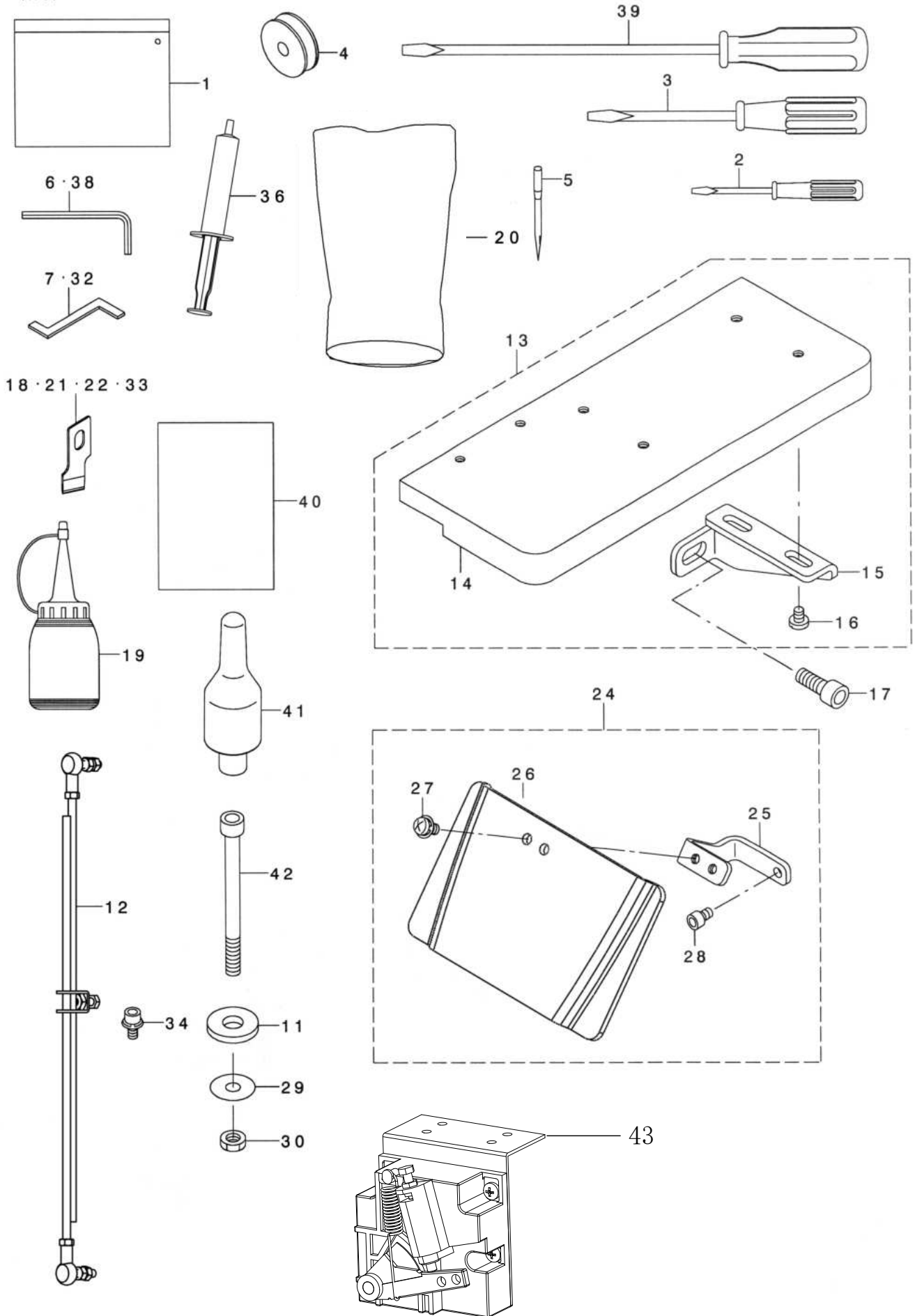

序号 NO	注解 Note	件号 Part NO.	名称	Description	数量 Qty
1		40131017	机头罩	ACCESSORIE BAG	1
2		10131004	一字螺丝刀 (小)	SCREW DRIVER, SMALL	1
3		10131003	一字螺丝刀 (中)	SCREW DRIVER, MIDDLE	1
4		4021800200	梭心	BOBBIN	1
5		40217002	机针#12	NEEDLE DP×5 #12 J-2	1
6		20131056	内六角扳手	HEXAGONAL WRENCH KEY	1
7	01	41312097	定时调节钩	HOOK TIMING GAUGE, K	1
8		-----			0
9		-----			0
10		-----			0
11		41322003	垫圈	RUBBER CUSHION(B)	4
12		41312014	拉杆组件	CONNECTING ROD COMPL.	1
13		4130101200	辅助桌板组件	AUXILIARY TABLE ASM.	1
14	41301012 (漆前)	301651 (漆后)	辅助桌板	AUXILIARY TABLE	1
15		41312090	托架	INSTALLING PLATE	2
16		413S11025	螺钉	SCREW 11/64-40 L=4.8	4
17		413S13005	螺钉M6×10	SCREW M6 L=10	2
18		40219012	切刀 1"	KNIFE 1	1
19		20131038	油壶组件	OILER	1
20		110211011	油壶	OIL B /	1
21		40219010	切刀5/8"	KNIFE 5/8	1
22		40219009	切刀1/2"	KNIFE 1/2	1
23		-----			0
24		4133100700	护眼板组件	ASSY SAFETY PLATE B	1
25		41312099	护眼板托架	SAFETY PLATE BESE	1
26		41311021	安全板	SAFETY PLATE	1
27		413S11028	螺钉组件	SCREW M4 L=8	2
28		S05115	螺钉M4×6	SCREW M4 L=6	1
29		41328001	垫片	WASHER 6.1×18.5×2	4
30		205S16005	螺母M6	NUT M6	4
31		-----			0
32	02	141331001	定时调节钩	TIMING GAUGE, DMESTIC USE.	1
33		40219011	切刀3/8"	KNIFE 3/8	1
34		413S13008	螺钉组件	BOLT	1
35		-----			0
36		11411029	润滑脂	GREASE A TUBE	1
37		-----			0
38		30131012	内六角扳手	HEXAGONAL SPANNER	1
39		10131002	螺丝刀(大)	SCREW DRIVER, LARGE	1
40		41331030	说明书	EC PRODUCTION DECLARATION	1
41		40311002	机头支撑柱	HEAD SUPPORT BAR	1
42		413S13006	螺栓M6×70	HEXAGON BOLT	4
43		40331617	调速器	Speed controller	1

NOTE (注解) 01... FOR 1790S 1790S用
02... FOR 1790K 1790K用

14. THREAD STAND COMPONENTS

线架部件

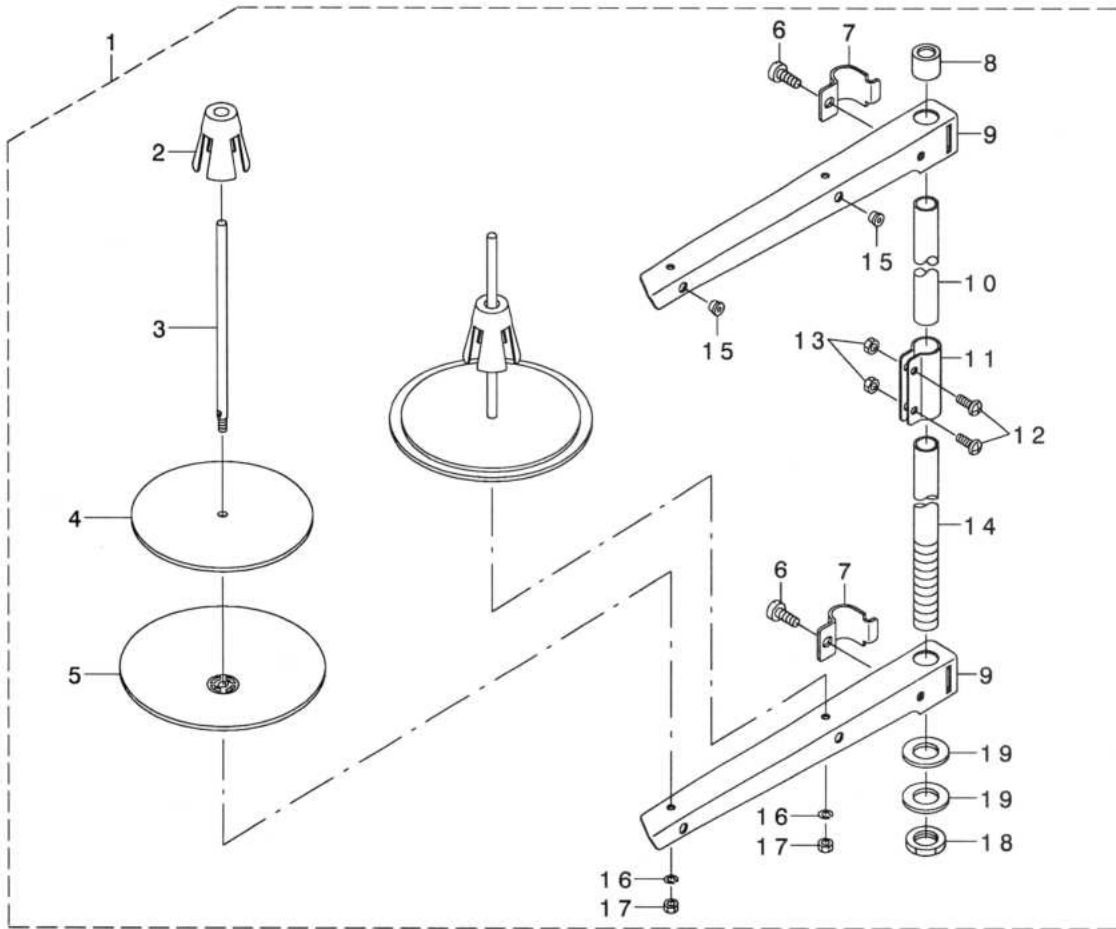

序号 NO	注解 Note	件号 Part NO.	名称	Description	数量 Qty
1		1383100300	过线架组件	THREAD STAND ASM.	1
2		-----	线架缓冲支架	SPOOL RETAINER	2
3		-----	线轴	SPOOL PIN	2
4		-----	线盘软垫	SPOOL REST CUSHION	2
5		-----	线盘	SPOOL REST	2
6		-----	螺钉	SCREW M6 L=16	2
7		-----	过线架固定夹	THREAD GUIDE ARM JOINT	2
8		-----	线架支撑套	SPOOL REST ROD RUBBER CAP	1
9		-----	线架	SPOOL REST ARM	2
10		-----	线架支撑管 1	SPOOL REST ROD, UPPER	1
11		-----	支撑管接头	SPOOL REST ROD JOINT	1
12		-----	螺钉	SCREW M5 L=14	2
13		-----	螺母	NUT M5	2
14		-----	线架支撑管 2	SPOOL REST ROD, LOWER	1
15		-----	过线套	THREAD GUIDE	2
16		-----	弹簧垫圈	SPRING WASHER	2
17		-----	螺母	NUT M5	2
18		-----	螺母	NUT M16X1.5	1
19		-----	垫片	WASHER 17X30X2.6	2

15. SPECIAL SPECIFICATIONS COMPONENTS

特殊类型部件

LARGE SIZE TYPE (FOR 70MM, 120MM)
大尺寸类型 (70MM, 120MM用)

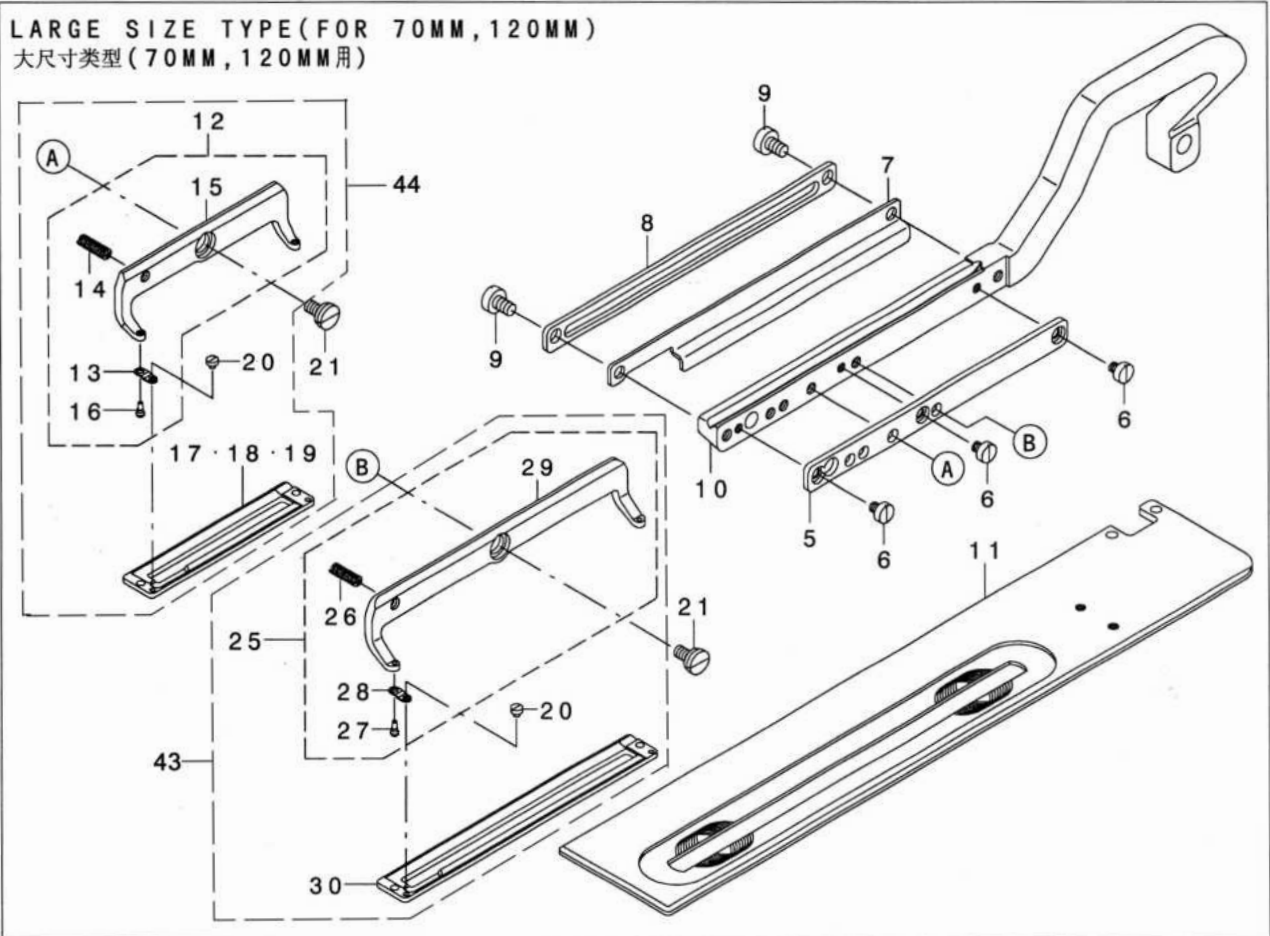

SHORT THREAD TYPE

短线头类型

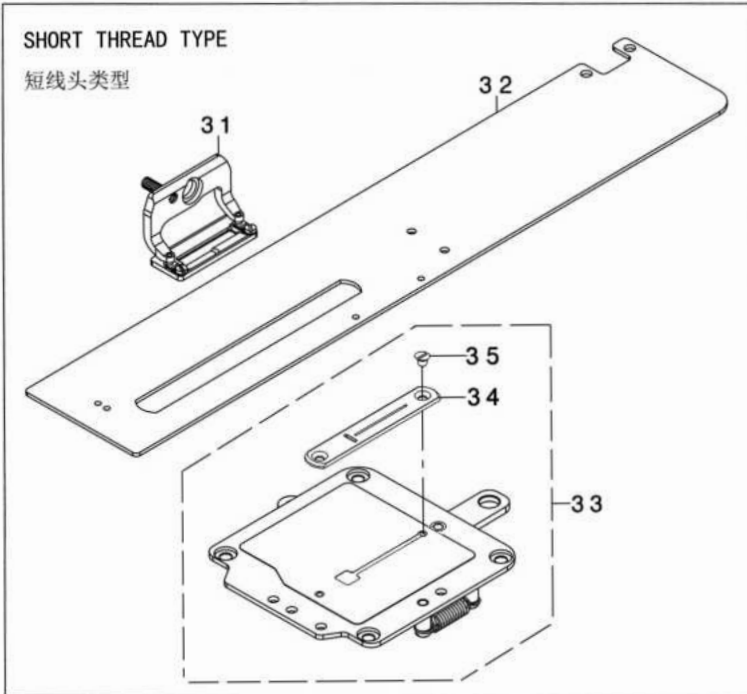

KNITTING TYPE

针织类型

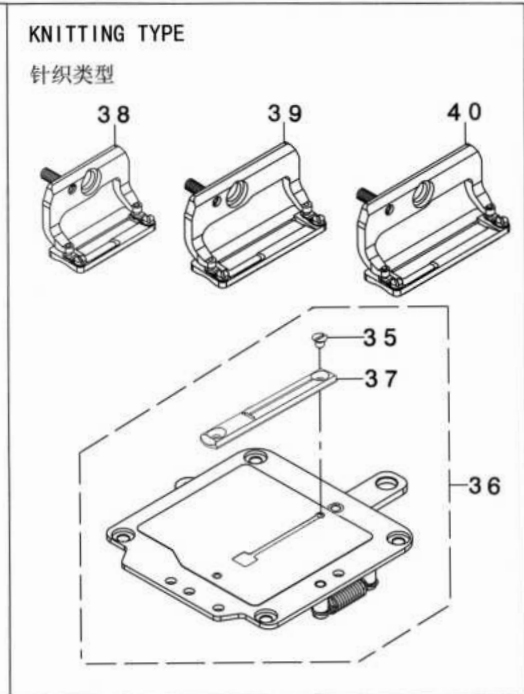

序号 NO	注解 Note	件号 Part NO.	名称	Description	数量 Qty
1		-----			0
2		-----			0
3		-----			0
4		-----			0
5		41312103	压脚板座垫片	WORK CLAMP HOLDER SPACE	1
6		413S11013	螺钉	SCREW M4 L=4	3
7		41312104	剪线板	UTT CLOSE CAM 120B	1
8		41312105	压脚送料导向板	LIFTING PLATE 120	1
9		413S11018	螺钉M5×8	SCREW M5 L=8	2
10		41316007	压脚支架	WORK CLAMP ARM 120	1
11		41312106	送布拖板	WORK CLAMP CARRIER 120	1
12		4131600200	压脚组件(70)	PRESSER FOOT 70 ASM.	1
13		40212018	压脚弹簧板	PRESSER FITTING PLATE SPING	2
14		40227003	压脚板座弹簧	PRESSER FOOT HOLDER SPRING	1
15		41316003	压脚板座(70)	PRESSER FOOT 70	1
16		40226008	压脚弹簧定位销	BRESSER FOOT PIN B	2
17		41316004	压脚板	URETHANE PRESSER 70	1
18		41316005	压脚板	PRESSER 70 (FLAT)	1
19		41316006	压脚板	PRESSER70	1
20		413S11029	螺钉	SCREW 3/32-56 L=1.9	6
21		402S20002	压脚螺钉	HINGE SCREW D=7.94 H=2	3
22		-----			0
23		-----			0
24		-----			0
25		4131600900	压脚组件(120)	ASSY WORK CLAMP CHECH HOLDER I	1
26		41327018	压脚板座弹簧	WORK CLAMP CHECK HOLDER SPRING	1
27		41326035	压脚弹簧定位销	WORK CLAMP CHECK SPRING SET PI	2
28		41312109	压脚弹簧板	WORK CLAMP CHECK SPRING	2
29		41316010	压脚板座(120)	WORK CLAMP CHECK HOLDER 120	1
30		41316011	压脚板(120)	WORK CLAMP 120	1
31		4131602700	压脚组件	ASSY WORK CLAMP CHECH HOLDER	1
32		41312037	送布拖板	WORK CLAMP CARRIER	1
33		4131501000	针板组件	THROAT PLATE BASE UNIT	1
34		41315011	针板	THROAT PLATE BASE	1
35		413S17002	螺钉	SCREW	1
36		14131500200	针板组件	THROAT PLATE BASE UNIT	1
37		41315001	针板	THROAT PLATE BASE	1
38		14131600100	压脚组件	ASSY WORK CLAMP CHECH HOLDER	1
39		14131600500	压脚组件	ASSY WORK CLAMP CHECH HOLDER	1
40		14131600800	压脚组件	ASSY WORK CLAMP CHECH HOLDER	1
41		-----			0
42		-----			0
43		4131601000	压脚组件	WORK CLAMP CHECK HOLDER ASM	1
44		4131602800	压脚组件	WORK CLAMP CHECK HOLDER ASM	1

16. BOTTOM LINE DETECTION MECHANISM(OPTION PARTS)
 底线检测装置(选配)

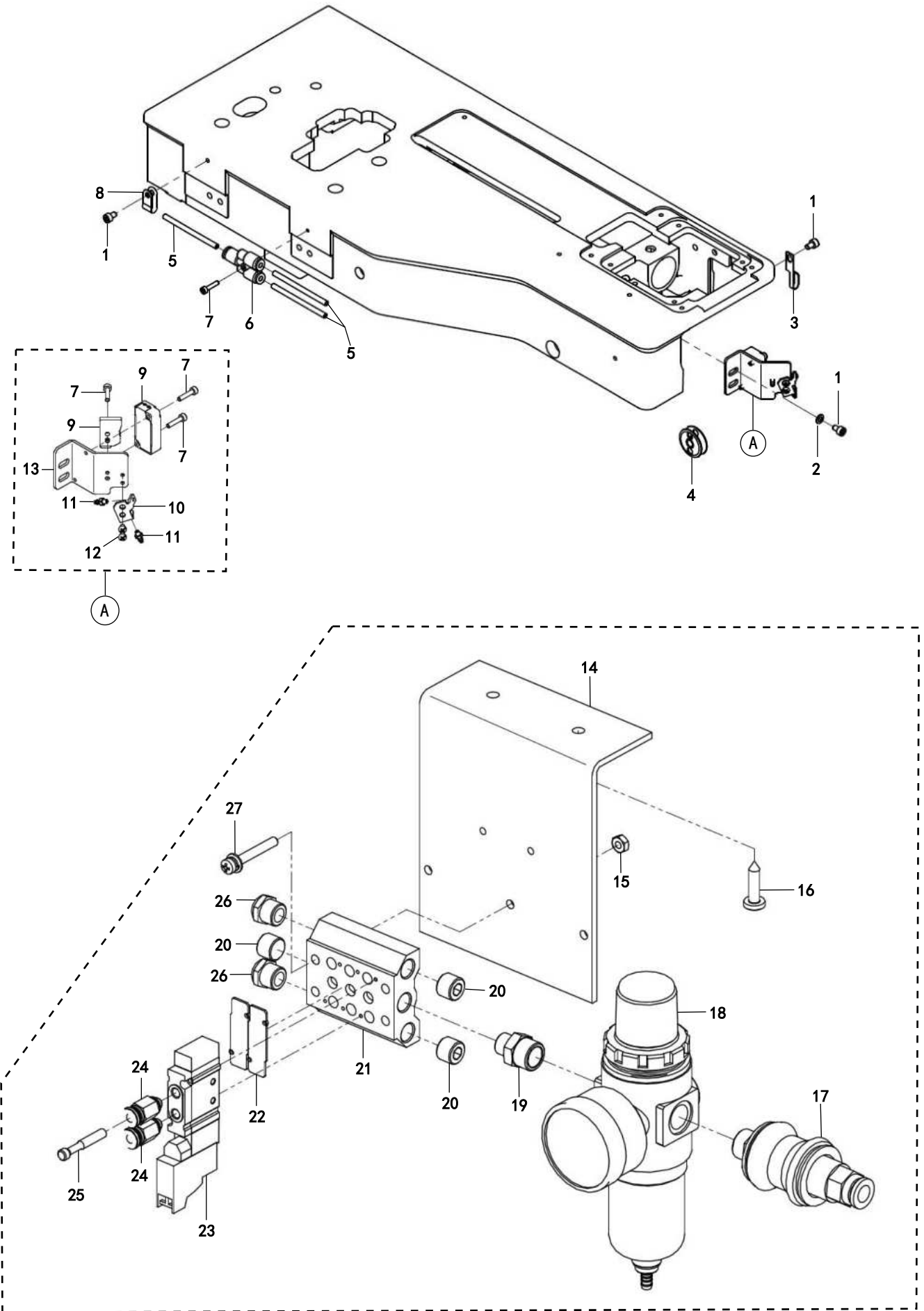

序号 NO	注解 Note	件号 Part NO.	名称	Description	数量 Qty
1		413S13003	螺钉M4×6	SCREW M4 L=6	4
2		41328023	垫圈	WASHER M4	2
3		41312003	油管固定架	LUBRICATING OIL WICK	1
4		141312002	底线检测窄槽梭心	BOBBIN OF BOTTOM LINE DETECTION	2
5		41845224	气管 φ4×2.5黑色	AIR TUBE (BLACK)	3
6		40736036	气管接头APY4	GAS-TYPE FITTING APY4	1
7		413S14012	内六角圆柱头螺钉	HEXAGON SOCKET HEAD CAP SCREW	4
8		41311001	线夹	CABLE CLAMP	1
9		14183000400	底线检测传感器	SENSOR OF BOTTOM LINE DETECTION	1
10		141312011	气嘴支架	SUPPORT OF NIPPLE	1
11		42136010	气管接头	GAS-TYPE FITTING	2
12		413S11022	十字螺钉	SCREW M3 L=4	2
13		141312007	传感器支架	SUPPORT OF SENSOR	1
14		41712106	阀安装板	SETTING PLATE VALVE	1
15		N01024	螺母	NUT M4	2
16		S16001	自攻螺钉	SELF-TAPPING SCREW ST4.8 L=20	2
17		42130096	手动开关VHK3	VALVE VHK3	1
18		141845004	气源处理元件	AIR SOURCE PROCESSOR	1
19		417S30026	管接头	FITTING	1
20		407S12002	汇流板密封螺钉	SCREW	3
21		41730014	连阀座	MANIFLOD 7V0500M3F	1
22		41730015	盲板	BLANKING PLATE ASSY P-7V0500M-R2	2
23		41730012	电磁阀	SOLENOID VALVE	1
24		41730013	电磁阀接头	FITTING	2
25		42122001	快换插头	PLUG	1
26		40728003	消声器	SILENCER	2
27		417S30024	十字槽小盘头螺钉	SCREW	2

17. THE INTERNET OF THINGS COMPONENTS (OPTION PARTS)
 物联网部件 (选配)

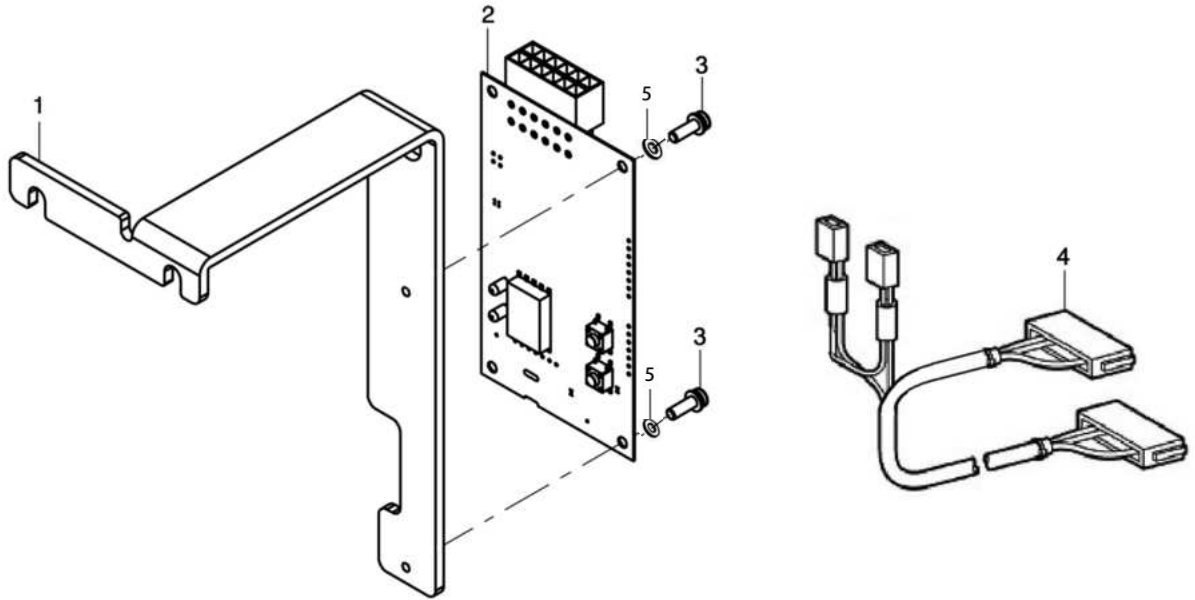

序号 NO	注解 Note	件号 Part NO.	名称	Description	数量 Qty
1		141312010	电路板安装板	CIRCUIT BOARD MOUNTING BOARD	1
2		140330005	物联网电路板	INTERNET OF THINGS CIRCUIT BORAD	1
3		413S13026	螺钉组件	SCREW COMPONENTS	2
4		141330010	物联网连接线	INTERNET OF THINGS CONNECTION	1
5		20122033	垫片	SHIM	4